

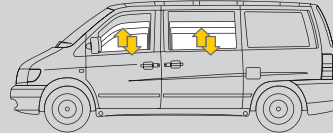

# SPAL

**AUTOMOTIVE**

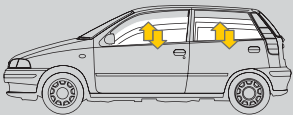

- ALZACRISTALLI ELETTRICI ANTERIORI E POSTERIORI • ELEKTRISCHE FENSTERHEBER FÜR VORDER-UND HINTERTÜREN • ALZACRISTALES ELETTRICOS DELANTEROS Y TRASEROS • LEVE-VITRES ELECTRIQUES AVANT ET ARRIERE • ELEKTRISCHE RAAMBEDIENING VOOR VOOR- EN ACHTERPORTIEREN • FRONT AND REAR ELECTRIC POWER WINDOWS • ЭЛЕКТРИЧЕСКИЕ СТЕКЛОПОДЪЕМНИКИ ДЛЯ ПЕРЕДНИХ И ЗАДНИХ СТЕКОЛ
- VIDROS ELÉTRICOS DIANTEIROS E TRASEIROS • ELEKTROMOS ABLAKEMELŐK ELSŐ ÉS HÁTSÓ AJTÓKHOZ



**12 V - 24 V**

**2ND-RELEASE**  
**MADE IN ITALY**

12V 24V

UNIVERSAL APPLICATIONS

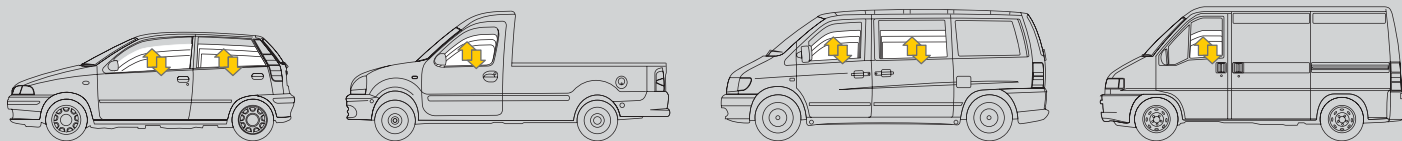

Anteriori • Vordertüren • Delanteros • Avant • Front • Voor • передних • Dianteiros • Első

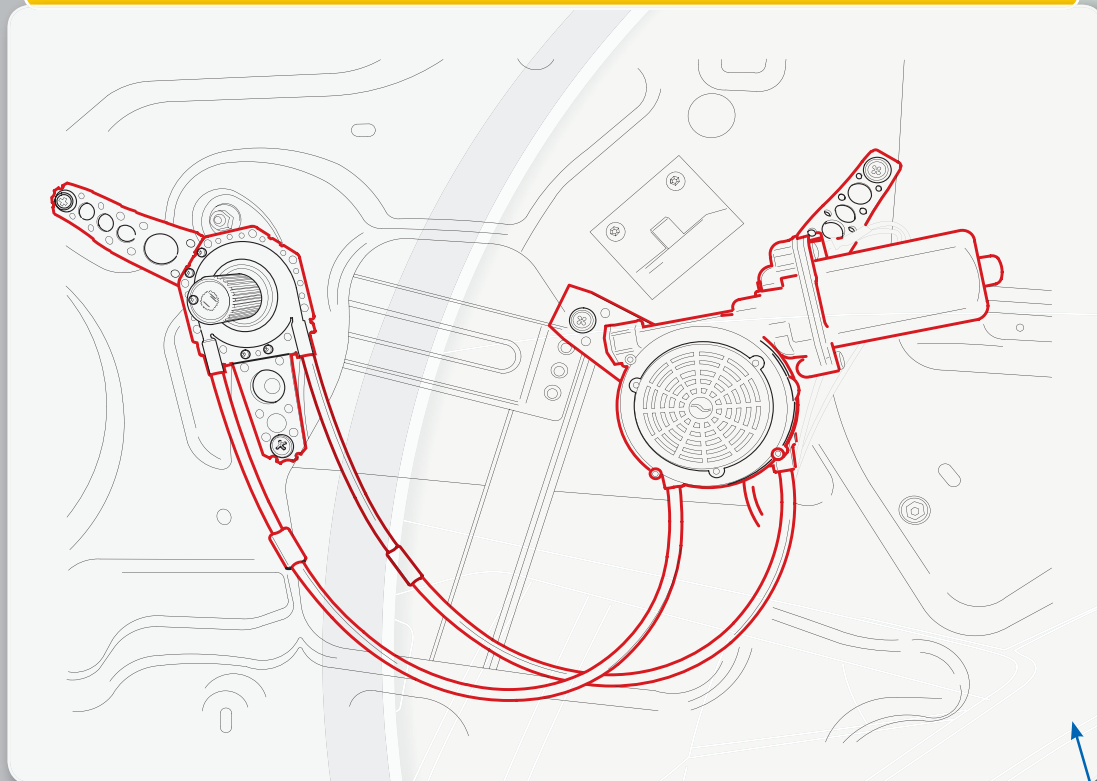

**Low Noise** *Very Long Life*



only  
0,8 cm

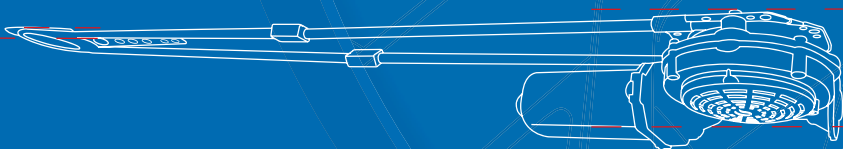

only  
5 cm



[www.spal.it](http://www.spal.it)



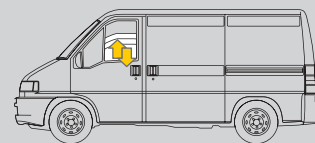
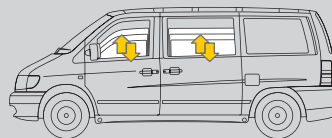
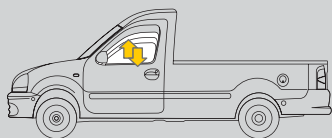
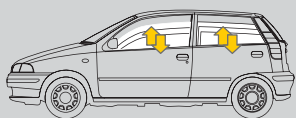

Posteriori • Hintertüren • Traseros • Arriere • Rear • Achter • задних • Traseiros • Hátsó

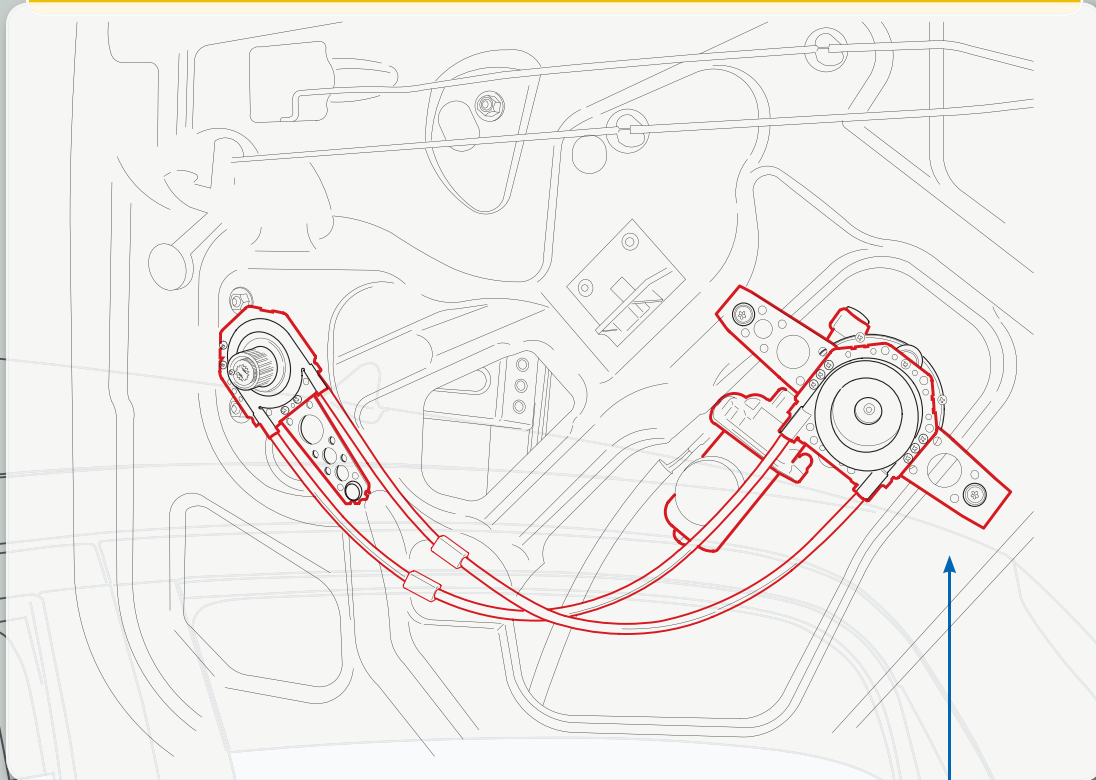

Optional

cod. 3304.0000

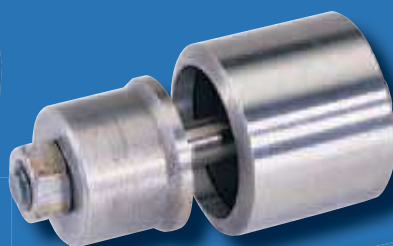

**Alzacristalli elettrici  
anteriori e posteriori**

**Elektrische Fensterheber für  
Vorder-und Hintertüren**

**Alzacristales Elétricos  
Delanteros y Traseros**

**Lève-Vitres Electriques  
Avant et Arrière**

**Elektrische Raambediening  
Voor Voor- en Achterportieren**

**Front and Rear Electric  
Power Windows**

**Электрические  
стеклоподъемники  
для передних и задних стекол**

**Vidros elétricos  
dianteiros e traseiros**

**Elektromos ablakemelők első és  
hátsó ajtókhöz**



## INDICE GENERALE

	<b>ALZACRISTALLI ELETTRICI</b> ELEKTRISCHE FENSTERHEBER • ALZACRISTALES ELETRICOS • LÈVE-VITRES ÉLECTRIQUES • ELEKTRISCHE RAAMBEDIENING • ELECTRIC POWER WINDOWS • ЭЛЕКТРИЧЕСКИЕ СТЕКЛОПОДЪЕМНИКИ • VIDROS ELÉTRICOS • ELEKTROMOS ABLAKEMELŐK ..... 4
	<b>KIT INTERRUTTORI</b> KIT SCHALTER • KIT PULSADORES • KIT INTERRUPTEURS • KIT SCHAKELAARS • SWITCH KIT • КОМПЛЕКТЫ КНОПОК СТЕКЛОПОДЪЕМНИКОВ • KIT DE INTERRUPTORES • KAPCSOLÓKÉSZLET
	UNIVERSAL push&pull.....5-6-7-8-20
	UNIVERSAL .....9-10-11-12-13-14-15-16-17
	BMW .....18
	FIAT .....8
	MERCEDES .....18
	OPEL .....18-19
	RENAULT .....12
	<b>INTERRUTTORI ED ACCESSORI</b> SCHALTER UND ZUBEHÖR • PULSADORES Y ACCESORIOS • INTERRUPTEURS ET ACCESSOIRES • SCHAKELAARS EN ACCESSOIRES • SWITCH AND OPTIONAL ACCESSORIES • КНОПКИ И ДОПОЛНИТЕЛЬНЫЕ АКСЕССУАРЫ • INTERRUPTORES E ACESSÓRIOS • KAPCSOLÓK ÉS KIEGÉSZÍTŐK .....21-22-23
	<b>CABLAGGI</b> KABELSÄTZE • CABLEADOS • CÂBLAGES • KABELS • WIRE HARNESS • КОМПЛЕКТЫ ПРОВОДОВ • CHICOTES ELÉTRICOS • KÁBELKÖTEGEK .....24-25
	<b>TRANCIATORE</b> LOCHSCHNEIDER • SACABOCADOR • CISAILLEUR • PONS VOOR DEURPANEEL • CUTTER • НОЖ • CORTADOR • KIVÁGÓSZERSZÁM.....26
	<b>MODULI ALZACRISTALLI</b> ELEKTRONISCHE STEUERUNG • MÓDULO ALZACRISTALES • MODULES LEVE-VITRES • MODULE VOOR RAAMBEDIENING • ELECTRONIC WINDOWS MODULE • МОДУЛИ ЭЛЕКТРИЧЕСКИХ СТЕКЛОПОДЪЕМНИКОВ • MÓDULOS ELEVADORES DE VIDROS • ABLAKEMELŐ MODULOK .....27
	<b>SOMMARIO</b> INHALT • SUMARIO • SOMMAIRE • SUMMARY • SAMENVATTING • ПОИСК ПО КОДУ • SUMÁRIO • NÉVMUTATÓ .....28

## ALZACRISTALLI ELETTRICI

ELEKTRISCHE FENSTERHEBER • ALZACRISTALES ELETTRICOS • LÈVE-VITRES ÉLECTRIQUES • ELEKTRISCHE RAAMBEDIENING • ELECTRIC POWER WINDOWS • ЭЛЕКТРИЧЕСКИЕ СТЕКЛОПОДЪЕМНИКИ • VIDROS ELÉTRICOS • ELEKTROMOS ABLAKEMELŐK

12V

KIT cod. 3300.0013

24V

KIT cod. 3300.1000

- **KIT 2 ALZACRISTALLI ELETTRICI**  
con **termico** applicabili alle portiere anteriori e posteriori di qualsiasi tipo di autoveicolo.
- **KIT 2 ELEKTRISCHE FENSTERHEBER**  
mit **Thermoschalter** für Vorder und Hintertüren aller Kraftfahrzeuge.
- **KIT 2 ALZACRISTALES ELECTRICOS**  
con **termico**, adaptable a las puertas delanteras y traseras de cualquier tipo de vehículo.
- **KIT 2 LÈVE-VITRES ÉLECTRIQUES**  
avec **protection thermique**, pour portes avant et arrière adaptable sur tous types de véhicules.
- **KIT 2 ELEKTRISCHE RAAMBEDIENINGEN**  
met **slipkoppeling**, passend op voor- en achterportieren van elk type auto.
- **KIT 2 ELECTRIC POWER WINDOWS**  
with **thermal control** applicable on the front and rear doors of each type of cars.
- **КОМПЛЕКТ ИЗ 2 ЭЛЕКТРИЧЕСКИХ СТЕКЛОПОДЪЕМНИКОВ**  
**со встроенным термозащитителем** для установки в передние и задние двери автомобилей любых марок и моделей.
- **KIT DE 2 VIDROS ELÉTRICOS**  
com **proteção térmica**, aplicáveis nas portas dianteiras e traseiras de qualquer tipo de veículo.
- **KÉSZLET 2db ELEKTROMOS ABLAKEMELŐVEL**  
**hőkioldós**, bármely típusú gépkocsi első és hátsó ajtajára felszerelhető.



12V - KIT COD. 3300.0013: e1 03 5875  
24V - KIT COD. 3300.1000: e1 03 5874

- **KIT 2 ALZACRISTALLI ELETTRICI "DE LUXE"**  
**termico**, estremamente silenziosi, applicabili alle portiere anteriori e posteriori di qualsiasi tipo di autoveicolo (provvista di maniglia di emergenza da usare nel caso di guasto all'impianto elettrico).
- **KIT 2 ELEKTRISCHE FENSTERHEBER "DE LUXE"**  
mit **Thermoschalter**, Geräuscharm für Vorder- und Hintertüren aller Kraftfahrzeuge (Mit Nothandkurbel für den Fall einer Störung der elektrischen Anlage).
- **KIT 2 ALZACRISTALES ELECTRICOS "DE LUXE"**  
con **termico**, adaptable a las puertas delanteras y traseras de cualquier tipo de vehículo (provisto de manivela de emergencia para usar en caso de dañarse o averiarse la instalación eléctrica).
- **KIT 2 LÈVE-VITRES ÉLECTRIQUES "DE LUXE"**  
avec **thermique**, extrêmement silencieux, pour portes avant et arrière adaptable sur tous types de véhicules, (fourni avec une manivelle de secours qui permet de remonter manuellement les vitres en cas de panne électrique).
- **KIT 2 ELEKTRISCHE RAAMBEDIENINGEN "DE LUXE"**  
met **thermokoppeling**, buitengewoon geruisloos, passend op voor- en achterportieren van elk type auto. (Een noodhendel is ingesloten, zodat bij een elektrische storing de ramen handmatig gesloten kunnen worden).
- **KIT 2 ELECTRIC POWER WINDOWS "DE LUXE"**  
with **thermal control**, extremely noiseless, applicable on the front and rear doors of each type of cars (equipped with emergency handle to use in case of loss of electrical power).
- **КОМПЛЕКТ ИЗ 2 ЭЛЕКТРИЧЕСКИХ СТЕКЛОПОДЪЕМНИКОВ "DE LUXE"**  
**со встроенным термозащитителем**, с пониженным уровнем шума, для установки в передние и задние двери автомобилей любых марок и моделей (комплектуется ручкой для экстренного открытия стекла в случае поломки стеклоподъемника).

e1 03 5873

12V

KIT cod. 3300.0021



- **KIT DE 2 VIDROS ELÉTRICOS "DE LUXE"**  
com **proteção térmica**, extremamente silenciosos, aplicáveis nas portas dianteiras e traseiras de qualquer tipo de veículo (fornecido com manivela de emergência para ser utilizada em caso de avaria no sistema elétrico).
- **KÉSZLET 2db "DE LUXE" ELEKTROMOS ABLAKEMELŐVEL**  
rendkívül csendesen működik, bármely típusú gépkocsi első és hátsó ajtajára felszerelhető, **hőkioldós** (mechanikus ablakemelő kart tartalmaz, amelyet az elektromos rendszer hibája esetén lehet használni).



**KIT cod. 3304.0174**

**• KIT UNIVERSALE PUSH & PULL CON CORNICI**

completo di: 3 pulsanti Cod. 1740.0114, 1 cornice singola Cod. 3303.0115, 1 cornice doppia parallela Cod. 3303.0116, 1 cornice doppia Cod. 3303.0117, 1 cablaggio Cod. 3302.0025.

**• KIT UNIVERSAL PUSH & PULL MIT RAHMEN**

bestehend aus: 3 Schalter Cod.1740.0114, 1 Einzelrahmen Cod.3303.0115, 1 Doppelrahmen parallele Cod.3303.0116, 1 Doppelrahmen Cod.3303.0117, 1 Kabelsatz Cod.3302.0025.

**• KIT UNIVERSAL PUSH & PULL CON SOPORTES**

compuesto de: 3 pulsadores Cod.1740.0114, 1 soporte sencillo Cod.3303.0115, 1 soporte doble paralelo Cod.3303.0116, 1 soporte doble Cod.3303.0117, 1 cableado Cod.3302.0025.

**• KIT UNIVERSEL PUSH & PULL AVEC SUPPORTS**

comprend: 3 interrupteurs Cod.1740.0114, 1 support simple Cod.3303.0115, 1 support double parallèle Cod.3303.0116, 1 support double Cod.3303.0117, 1 câblage Cod.3302.0025.

**• KIT UNIVERSEEL PUSH & PULL MET FRAMES**

bestaande uit: 3 schakelaars Cod.1740.0114, 1 Enkele frame Cod.3303.0115, 1 Dubbel frame evenwijdig Cod.3303.0116, 1 Dubbel frame Cod.3303.0117, 1 kabelset Cod.3302.0025.

**• KIT UNIVERSAL PUSH & PULL WITH FRAMES**

complete with: 3 switches Cod.1740.0114, 1 single frame Cod.3303.0115, 1 double frame parallel Cod.3303.0116 1 double frame Cod.3303.0117, 1 wire harness Cod.3302.0025.

**• УНИВЕРСАЛЬНЫЙ КОМПЛЕКТ КНОПОК PUSH & PULL С РАМКАМИ**

комплектуются: 3 кнопками Cod.1740.0114, 1 односекционной рамкой Cod.3303.0115, 1 двухсекционной параллельной рамкой Cod.3303.0116, 1 двухсекционной рамкой Cod.3303.0117, 1 комплектом проводов Cod.3302.0025.

**• KIT UNIVERSAL PUSH & PULL COM MOLDURAS**

composto por: 3 botões Cód. 1740.0114, 1 moldura simples Cód. 3303.0115, 1 moldura dupla paralela Cód. 3303.0116, 1 moldura dupla Cód. 3303.0117, 1 chicote elétrico Cód. 3302.0025.

**• UNIVERZÁLIS, KERETES HÚZÓ-NYOMÓ KÉSZLET**

tartalma: 3 nyomógomb Cod. 1740.0114, 1 szimpla keret Cod. 3303.0115, 1 dupla párhuzamos keret Cod. 3303.0116, 1 dupla keret Cod. 3303.0117, 1 kábelköteg Cod. 3302.0025.

3 x Cod. 1740.0114

1 x Cod. 3302.0025

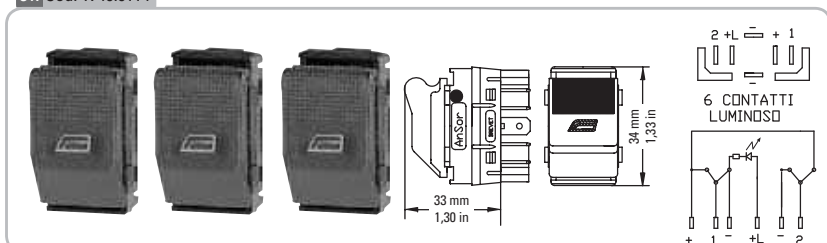

1 x Cod. 3303.0115

1 x Cod. 3303.0116

1 x Cod. 3303.0117

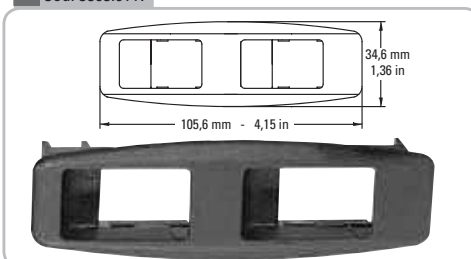
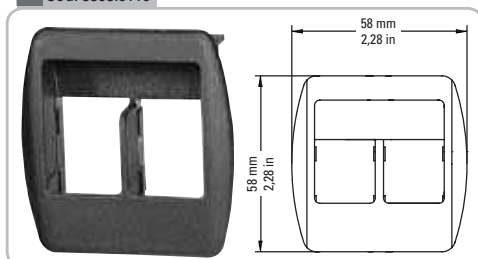
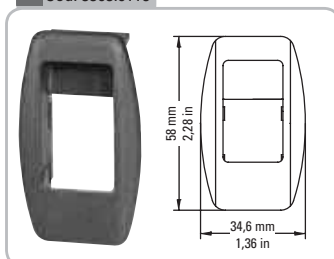

### • KIT UNIVERSALE PUSH & PULL CON CORNICI

completo di: 2 pulsanti Cod. 1740.0110A, 2 cornici singole Cod. 3303.0097, 1 cablaggio Cod. 3302.0018.

### • KIT UNIVERSAL PUSH & PULL MIT RAHMEN

bestehend aus: 2 Schalter Cod. 1740.0110A, 2 Einzelrahmen Cod. 3303.0097, 1 Kabelsatz Cod. 3302.0018.

### • KIT UNIVERSAL PUSH & PULL CON SOPORTE

compuesto de: 2 pulsadores Cod. 1740.0110A, 2 soportes sencillos Cod. 3303.0097, 1 cableado Cod. 3302.0018.

### • KIT UNIVERSEL PUSH & PULL AVEC SUPPORTS

comprend: 2 interrupteurs Cod. 1740.0110A, 2 supports simples Cod. 3303.0097, 1 câblage Cod. 3302.0018.

### • KIT UNIVERSEEL PUSH & PULL MET FRAMES

bestaande uit: 2 schakelaars Cod. 1740.0110A, 2 Enkele frames Cod. 3303.0097, 1 kabelset Cod. 3302.0018.

### • KIT UNIVERSAL PUSH & PULL WITH FRAMES

complete with: 2 switches Cod. 1740.0110A, 2 single frames Cod. 3303.0097, 1 wire harness Cod. 3302.0018.

### • УНИВЕРСАЛЬНЫЙ КОМПЛЕКТ КНОПОК PUSH & PULL С РАМКАМИ

комплектуется: 2 кнопками Cod. 1740.0110A, 2 односекционными рамками Cod. 3303.0097, 1 комплектом проводов Cod. 3302.0018.

### • KIT UNIVERSAL PUSH & PULL COM MOLDURAS

composto por: 2 botões Cód. 1740.0110A, 2 molduras simples Cód. 3303.0097, 1 chicote elétrico Cód. 3302.0018.

### • UNIVERZÁLIS, KERETES HÚZÓ-NYOMÓ KÉSZLET

tartalma: 2 nyomógomb Cod. 1740.0110A, 2 szimpla keret Cod. 3303.0097, 1 kábelköteg Cod. 3302.0018.



**KIT cod. 3304.0160**

2x Cod. 1740.0110A

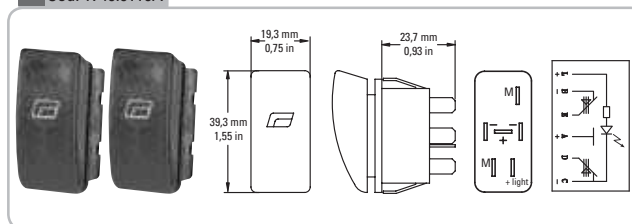

2x Cod. 3303.0097

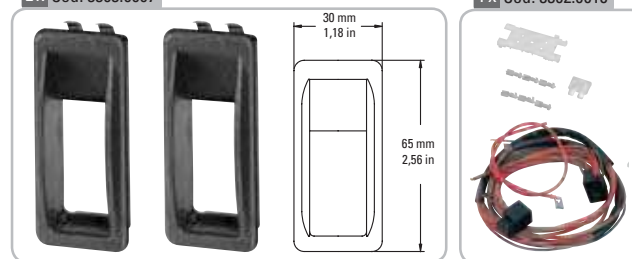

1x Cod. 3302.0018



### • KIT UNIVERSALE PUSH & PULL CON CORNICE DOPPIA

completo di: 2 pulsanti Cod. 1740.0110A, 1 cornice doppia Cod. 3303.0098, 1 cablaggio Cod. 3302.0018.

### • KIT UNIVERSAL PUSH & PULL MIT DOPPELRAHMEN

bestehend aus: 2 Schalter Cod. 1740.0110A, 1 Doppelrahmen Cod. 3303.0098, 1 Kabelsatz Cod. 3302.0018.

### • KIT UNIVERSAL PUSH & PULL CON SOPORTE DOBLE

compuesto de: 2 pulsadores Cod. 1740.0110A, 1 soporte doble Cod. 3303.0098, 1 cableado Cod. 3302.0018.

### • KIT UNIVERSEL PUSH & PULL AVEC SUPPORT DOUBLE

comprend: 2 interrupteurs Cod. 1740.0110A, 1 support double Cod. 3303.0098, 1 câblage Cod. 3302.0018.

### • KIT UNIVERSEEL PUSH & PULL MET DUBBELE FRAME

bestaande uit: 2 schakelaars Cod. 1740.0110A, 1 Dubbel frame Cod. 3303.0098, 1 kabelset Cod. 3302.0018.

### • KIT UNIVERSAL PUSH & PULL WITH DOUBLE FRAME

complete with: 2 switches Cod. 1740.0110A, 1 double frame Cod. 3303.0098, 1 wire harness Cod. 3302.0018.

### • УНИВЕРСАЛЬНЫЙ КОМПЛЕКТ КНОПОК PUSH & PULL С ДВУХСЕКЦИОННОЙ РАМКОЙ

комплектуется: 2 кнопками Cod. 1740.0110A, 1 двухсекционной рамкой Cod. 3303.0098, 1 комплектом проводов Cod. 3302.0018.

### • KIT UNIVERSAL PUSH & PULL COM MOLDURA DUPLA

composto por: 2 botões Cód. 1740.0110A, 1 moldura dupla Cód. 3303.0098, 1 chicote elétrico Cód. 3302.0018.

### • UNIVERZÁLIS, DUPLAKERETES HÚZÓ-NYOMÓ KÉSZLET

tartalma: 2 nyomógomb Cod. 1740.0110A, 1 dupla keret Cod. 3303.0098, 1 kábelköteg Cod. 3302.0018.



**KIT cod. 3304.0161**

2x Cod. 1740.0110A

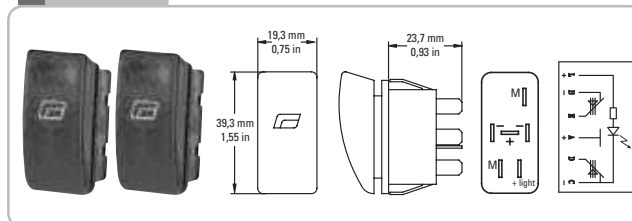

1x Cod. 3303.0098

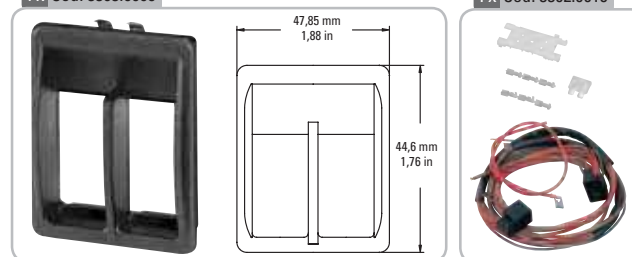

1x Cod. 3302.0018







KIT cod. 3304.0162

- **KIT UNIVERSALE PUSH & PULL CON CORNICI**  
completo di: 3 pulsanti Cod. 1740.0110A, 1 cornice singola Cod. 3303.0097, 1 cornice doppia Cod. 3303.0098, 1 cablaggio Cod. 3302.0022.
- **KIT UNIVERSAL PUSH & PULL MIT RAHMEN**  
bestehend aus: 3 Schalter Cod.1740.0110A, 1 Einzelrahmen Cod.3303.0097, 1 Doppelrahmen Cod.3303.0098, 1 Kabelsatz Cod.3302.0022.
- **KIT UNIVERSAL PUSH & PULL CON SOPORTES**  
compuesto de: 3 pulsadores Cod.1740.0110A, 1 soporte sencillo Cod.3303.0097, 1 soporte doble Cod.3303.0098, 1 cableado Cod.3302.0022.
- **KIT UNIVERSEL PUSH & PULL AVEC SUPPORTS**  
comprend: 3 interrupteurs Cod.1740.0110A, 1 support simple Cod.3303.0097, 1 support double Cod.3303.0098, 1 câblage Cod.3302.0022.
- **KIT UNIVERSEEL PUSH & PULL MET FRAMES**  
bestaande uit: 3 schakelaars Cod.1740.0110A, 1 Enkele frame Cod.3303.0097, 1 Dubbel frame Cod.3303.0098, 1 kabelset Cod.3302.0022.
- **KIT UNIVERSAL PUSH & PULL WITH FRAMES**  
complete with: 3 switches Cod.1740.0110A, 1 single frame Cod.3303.0097, 1 double frame Cod.3303.0098, 1 wire harness Cod.3302.0022.
- **УНИВЕРСАЛЬНЫЙ КОМПЛЕКТ КНОПОК PUSH & PULL С РАМКАМИ**  
комплектуется: 3 кнопками Cod.1740.0110A, 1 односекционной рамкой Cod.3303.0097, 1 двухсекционной рамкой Cod.3303.0098, 1 комплектом проводов Cod.3302.0022.
- **KIT UNIVERSAL PUSH & PULL COM MOLDURAS**  
composto por: 3 botões Cód. 1740.0110A, 1 moldura simples Cód. 3303.0097, 1 moldura dupla Cód. 3303.0098, 1 chicote elétrico Cód. 3302.0022.
- **UNIVERZÁLIS, KERETES HÚZÓ-NYOMÓ KÉSZLET**  
tartalma: 3 nyomógomb Cod. 1740.0110A, 1 szimpla keret Cod. 3303.0097, 1 dupla keret Cod. 3303.0098, 1 kábelköteg Cod. 3302.0022.

3 x Cod. 1740.0110A

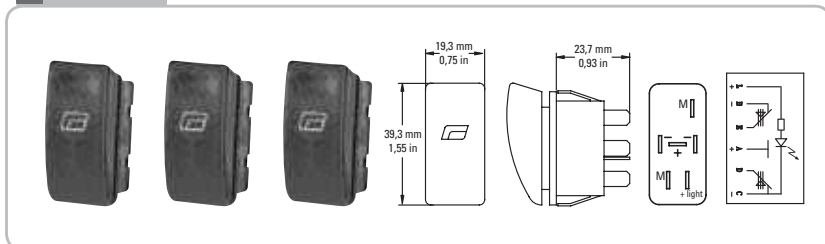

1 x Cod. 3302.0022



1 x Cod. 3303.0097

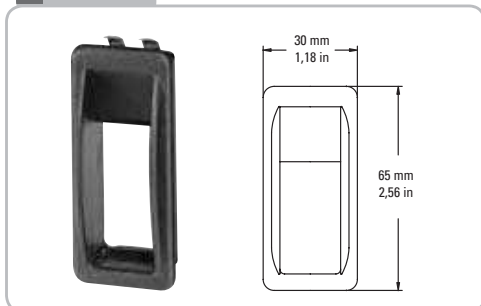

1 x Cod. 3303.0098

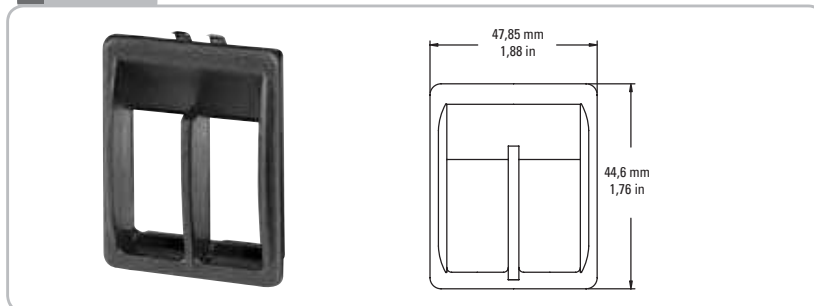



**KIT cod. 3304.0219**

- **KIT UNIVERSALE PUSH & PULL - FIAT PALIO SU PANNELLO**  
completo di: 3 pulsanti Cod. 1740.0110A, 2 cornici doppie cod. 3303.0098, 1 tappo copriforo Cod. 3303.0139, 2 supporti Cod. 3303.0140, 1 cablaggio Cod. 3302.0022.
- **KIT UNIVERSAL PUSH & PULL - FIAT PALIO AUF DER TÜRVERKEIDUNG**  
bestehend aus: 3 Schalter Cod.1740.0110A, 2 Doppelrahmen Cod.3303.0098, 1 Blindstopfen Cod.3303.0139, 2 Schalterkonsole Cod.3303.0140, 1 Kabelsatz Cod.3302.0022.
- **KIT UNIVERSAL PUSH & PULL - FIAT PALIO SOBRE PANEL**  
compuesto de: 3 pulsadores Cod.1740.0110A, 2 soportes doble Cod.3303.0098, 1 tapón Cod.3303.0139, 2 soportes Cod.3303.0140, 1 cableado Cod.3302.0022.
- **KIT UNIVERSEL PUSH & PULL - FIAT PALIO SUR PANNEAU**  
comprend: 3 interrupteurs Cod.1740.0110A, 2 supports double Cod.3303.0098, 1 obturateur Cod.3303.0139, 2 supports Cod.3303.0140, 1 câblage Cod.3302.0022.
- **KIT UNIVERSEEL PUSH & PULL - FIAT PALIO OP DEURPANEEL**  
bestaande uit: 3 schakelaars Cod.1740.0110A, 2 Dubbele frames Cod.3303.0098, 1 dop Cod.3303.0139, 2 frames Cod.3303.0140, 1 kabelset Cod.3302.0022.
- **KIT UNIVERSAL PUSH & PULL - FIAT PALIO ON DOOR CASING**  
complete with: 3 switches Cod.1740.0110A, 2 double frames Cod.3303.0098, 1 cap Cod.3303.0139, 2 frames Cod.3303.0140, 1 wire harness Cod.3302.0022.
- **УНИВЕРСАЛЬНЫЙ И FIAT PALIO КОМПЛЕКТ КНОПОК PUSH & PULL НА ДВЕРЬ**  
комплектуются: 3 кнопки Cod.1740.0110A, 2 двухсекционными рамками Cod.3303.0098, 1 заглушкой Cod.3303.0139, 2 рамками Cod.3303.0140, 1 комплектом проводов Cod.3302.0022
- **KIT UNIVERSAL PUSH & PULL - FIAT PALIO EM PAINEL**  
composto por: 3 botões Cód. 1740.0110A, 2 molduras duplas Cód. 3303.0098, 1 tampa cobre-furo Cód. 3303.0139, 2 suportes Cód. 3303.0140, 1 chicote elétrico Cód. 3302.0022.
- **UNIVERZÁLIS HÚZÓ-NYOMÓ - FIAT PALIO KÉSZLET KÁRPITON**  
tartalma: 3 nyomógomb Cod. 1740.0110A, 2 dupla keret Cod. 3303.0098, 1 nyílástakaró dugó Cod. 3303.0139, 2 tartókonzol Cod. 3303.0140, 1 kábelköteg Cod. 3302.0022.

3 x Cod. 1740.0110A

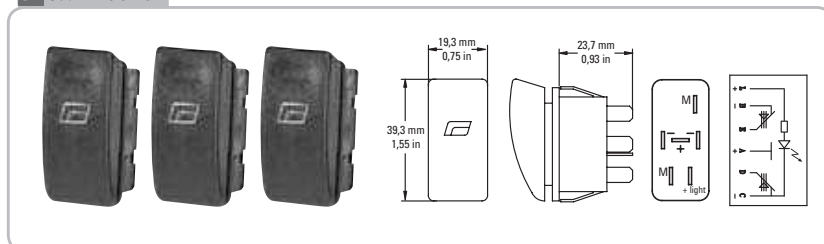

1 x Cod. 3302.0022



1 x Cod. 3303.0139

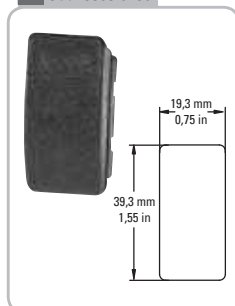

2 x Cod. 3303.0098

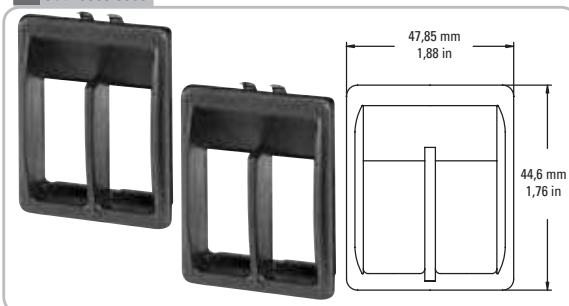

2 x Cod. 3303.0140

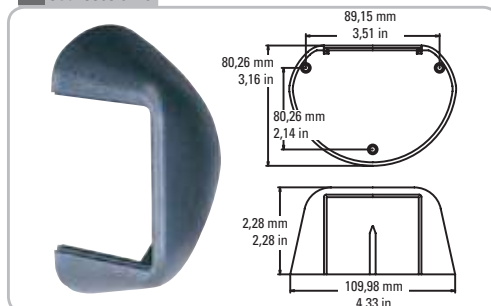



KIT cod. 3304.0167

- **KIT UNIVERSALE CON SUPPORTI**  
completo di: 3 pulsanti Cod. 1740.0111A, 1+1 supporti dx e sx Cod. 3303.0103, 1 cablaggio Cod. 3302.0032.
- **KIT UNIVERSAL MIT SCHALTERCONSOLE**  
bestehend aus: 3 Schalter Cod.1740.0111A, 1+1 Schalterconsole Cod.3303.0103 rechts und links, 1 Kabelsatz Cod.3302.0032.
- **KIT UNIVERSAL CON SOPORTES**  
compuesto de: 3 pulsadores Cod.1740.0111A, 1+1 soportes Cod.3303.0103 derecho y izquierdo, 1 cableado Cod.3302.0032.
- **KIT UNIVERSEL AVEC SUPPORTS**  
comprend: 3 interrupteurs Cod.1740.0111A, 1+1 supports Cod.3303.0103 droite et gauche, 1 câblage Cod.3302.0032.
- **KIT UNIVERSEEL MET FRAMES**  
bestaande uit: 3 schakelaars Cod.1740.0111A, 1+1 frame rechts en links Cod.3303.0103, 1 kabelset Cod.3302.0032.
- **KIT UNIVERSAL WITH FRAMES**  
complete with: 3 switches Cod.1740.0111A, 1+1 frames right and left Cod.3303.0103, 1 wire harness Cod.3302.0032.
- **УНИВЕРСАЛЬНЫЙ КОМПЛЕКТ КНОПОК С РАМКАМИ**  
комплектуются: 3 кнопками Cod.1740.0111A, 1+1 правой и левой рамками Cod.3303.0103, 1 комплектом проводов Cod.3302.0032.
- **KIT UNIVERSAL COM SUPORTES**  
compuesto por: 3 botões Cód. 1740.0111A, 1 + 1 suportes dir. e esq. Cód. 3303.0103, 1 chicote elétrico Cód. 3302.0032.
- **UNIVERZÁLIS KÉSZLET TARTÓKONZOLOKKAL**  
tartalma: 3 nyomógomb Cod. 1740.0111A, 1 + 1 jobbos és balos tartókonzol Cod. 3303.0103, 1 kábelköteg Cod. 3302.0032.

3x Cod. 1740.0111A

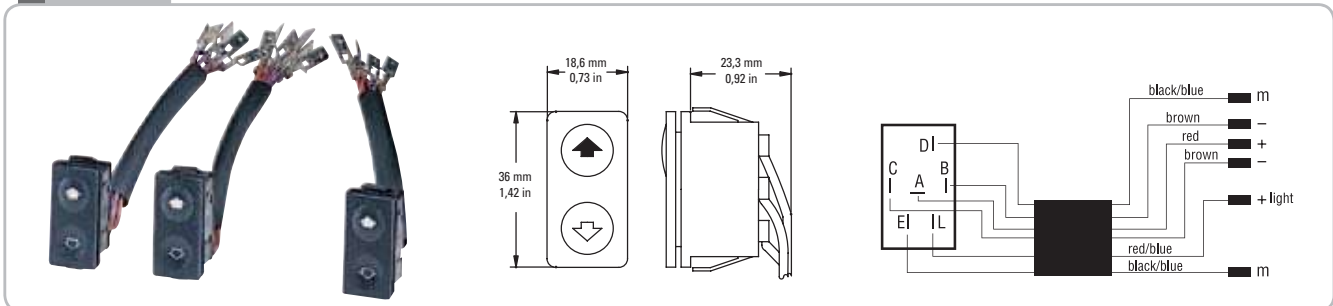

1+1x Cod. 3303.0103 Dx + Sx



1x Cod. 3302.0032



# KIT INTERRUITORI

KIT SCHALTER • KIT PULSADORES • KIT INTERRUPTEURS • KIT SCHAKELAARS • SWITCH KIT • КОМПЛЕКТЫ КНОПОК СТЕКЛОПОДЪЕМНИКОВ • KIT DE INTERRUPTORES • KAPCSOLÓKÉSZLET



**KIT cod. 3304.0188**

- **KIT 3 PULSANTI UNIVERSALI CON SUPPORTI**  
completo di: 3 pulsanti Cod.1740.0111A, 1 supporto singolo Cod.3303.0125, 1 supporto doppio Cod.3303.0127, 1 cablaggio Cod.3302.0032.
- **KIT 3 SCHALTER UNIVERSAL MIT SCHALTERKONSOLE**  
bestehend aus: 3 Schalter Cod.1740.0111A, 1 Schalterkonsole Cod.3303.0125, 1 Schalterkonsole Cod.3303.0127, 1 Kabelsatz Cod.3302.0032.
- **KIT 3 PULSADORES UNIVERSAL CON SOPORTES**  
compuesto de: 3 pulsadores Cod.1740.0111A, 1 soporte sencillo Cod.3303.0125, 1 soporte doble Cod.3303.0127, 1 cableado Cod.3302.0032.
- **KIT 3 INTERRUPTEURS UNIVERSELS AVEC SUPPORTS**  
comprend: 3 interrupteurs Cod.1740.0111A, 1 support simple Cod.3303.0125, 1 support double Cod.3303.0127, 1 câblage Cod.3302.0032.
- **KIT 3 SCHAKELAARS UNIVERSEEL MET FRAMES**  
bestaande uit: 3 schakelaars Cod.1740.0111A, 1 Enkele frame Cod.3303.0125, 1 Dubbel frame Cod.3303.0127, 1 kabelset Cod.3302.0032.
- **KIT 3 UNIVERSAL SWITCHES WITH FRAMES**  
complete with: 3 switch Cod.1740.0111A, 1 single frame Cod.3303.0125, 1 double frame Cod.3303.0127, 1 wire harness Cod.3302.0032.
- **УНИВЕРСАЛЬНЫЙ КОМПЛЕКТ ИЗ 3 КНОПОК С РАМКАМИ**  
комплектуются: 3 кнопками Cod.1740.0111A, 1 односекционной рамкой Cod.3303.0125, 1 двухсекционной рамкой Cod.3303.0127, 1 комплектом проводов Cod.3302.0032.
- **KIT DE 3 BOTÕES UNIVERSAIS COM SUPORTES**  
composto por: 3 botões Cód. 1740.0111A, 1 suporte simples Cód. 3303.0125, 1 suporte duplo Cód. 3303.0127, 1 chicote elétrico Cód. 3302.0032.
- **3 UNIVERZÁLIS NYOMÓGOMB TARTÓKONZOLOKKAL**  
tartalma: 3 nyomógomb Cod.1740.0111A, 1 szimpla tartókonzol Cod.3303.0125, 1 dupla tartókonzol Cod.3303.0127, 1 kábelköteg Cod.3302.0032.

3x Cod. 1740.0111A

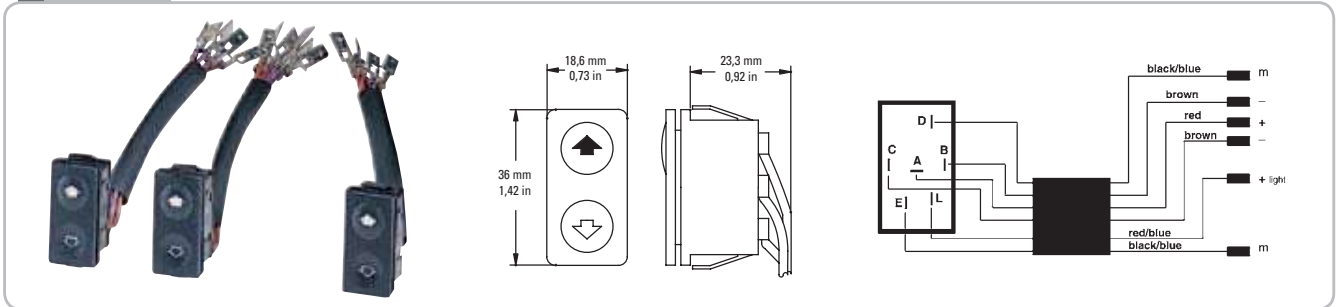

1x Cod. 3303.0125

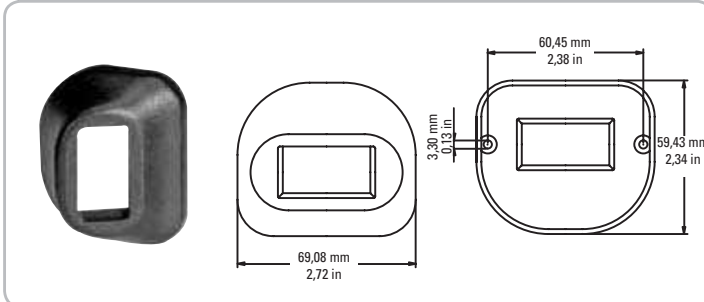

1x Cod. 3303.0127

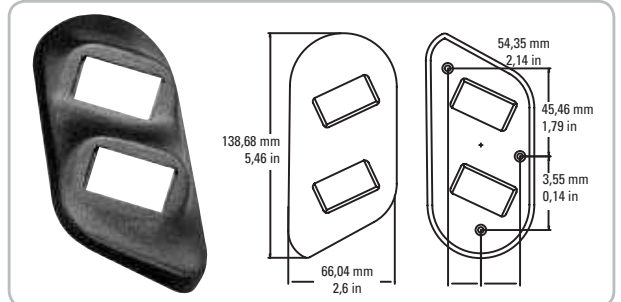

1x Cod. 3302.0032





KIT cod. 3304.0121

• **KIT UNIVERSALE CON CORNICI**

completo di: 2 pulsanti Cod.1740.0095A, 2 cornici singole Cod.3303.0079, 1 cablaggio Cod.3302.0018.

• **KIT UNIVERSAL MIT RAHMEN**

bestehend aus: 2 Schalter Cod.1740.0095A, 2 Einzelrahmen Cod.3303.0079, 1 Kabelsatz Cod.3302.0018.

• **KIT UNIVERSAL CON SOPORTE**

compuesto de: 2 pulsadores Cod.1740.0095A, 2 soportes sencillos Cod.3303.0079, 1 cableado Cod.3302.0018.

• **KIT UNIVERSEL AVEC SUPPORTS**

comprend: 2 interrupteurs Cod.1740.0095A, 2 supports simples Cod.3303.0079, 1 câblage Cod.3302.0018.

• **KIT UNIVERSEEL MET FRAMES**

bestaande uit: 2 schakelaars Cod.1740.0095A, 2 Enkele frames Cod.3303.0079, 1 kabelset Cod.3302.0018.

• **KIT UNIVERSAL WITH FRAMES**

complete with: 2 switches Cod.1740.0095A, 2 single frames Cod.3303.0079, 1 wire harness Cod.3302.0018.

• **УНИВЕРСАЛЬНЫЙ КОМПЛЕКТ КНОПОК С РАМКАМИ**

комплектуется: 2 кнопками Cod.1740.0095A, 2 односекционными рамками Cod.3303.0079, 1 комплектом проводов Cod.3302.0018.

• **KIT UNIVERSAL COM MOLDURAS**

compuesto por: 2 botões Cód. 1740.0095A, 2 molduras simples Cód. 3303.0079, 1 chicote elétrico Cód. 3302.0018.

• **UNIVERZÁLIS, KERETES KÉSZLET**

tartalma: 2 nyomógomb Cod. 1740.0095A, 2 szimpla keret Cod. 3303.0079, 1 kábelköteg Cod.3302.0018.

2 x Cod. 1740.0095A

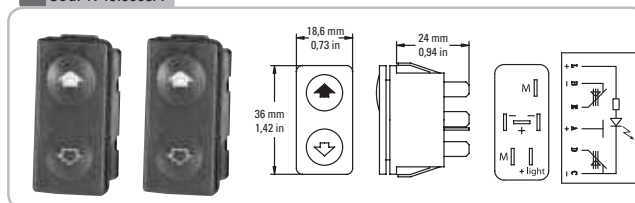

2 x Cod. 3303.0079

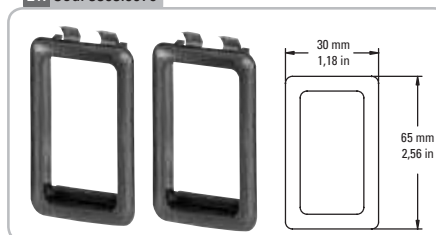

1 x Cod. 3302.0018



KIT cod. 3304.0122

• **KIT UNIVERSALE CON CORNICE DOPPIA**

completo di: 2 pulsanti Cod.1740.0095A, 1 cornice doppia Cod.3303.0081, 1 cablaggio Cod.3302.0018.

• **KIT UNIVERSAL MIT DOPPELRAHMEN**

bestehend aus: 2 Schalter Cod.1740.0095A, 1 Doppelrahmen Cod.3303.0081, 1 Kabelsatz Cod.3302.0018.

• **KIT UNIVERSAL CON SOPORTE DOBLE**

compuesto de: 2 pulsadores Cod.1740.0095A, 1 soporte doble Cod.3303.0081, 1 cableado Cod.3302.0018.

• **KIT UNIVERSEL AVEC SUPPORT DOUBLE**

comprend: 2 interrupteurs Cod.1740.0095A, 1 support double Cod.3303.0081, 1 câblage Cod.3302.0018.

• **KIT UNIVERSEEL MET DUBBEL FRAME**

bestaande uit: 2 schakelaars Cod.1740.0095A, 1 Dubbel frame Cod.3303.0081, 1 kabelset Cod.3302.0018.

• **KIT UNIVERSAL WITH DOUBLE FRAME**

complete with: 2 switches Cod.1740.0095A, 1 double frame Cod.3303.0081, 1 wire harness Cod.3302.0018.

• **УНИВЕРСАЛЬНЫЙ КОМПЛЕКТ КНОПОК С ДВУХСЕКЦИОННОЙ РАМКой**

комплектуется: 2 кнопками Cod.1740.0095A, 1 двухсекционной рамкой Cod.3303.0081, 1 комплектом проводов Cod.3302.0018.

• **KIT UNIVERSAL COM MOLDURA DUPLA**

compuesto por: 2 botões Cód. 1740.0095A, 1 moldura dupla Cód. 3303.0081, 1 chicote elétrico Cód. 3302.0018.

• **UNIVERZÁLIS, DUPLA KERETES KÉSZLET**

tartalma: 2 nyomógomb Cod. 1740.0095A, 1 dupla keret Cod. 3303.0081, 1 kábelköteg Cod.3302.0018.

2 x Cod. 1740.0095A

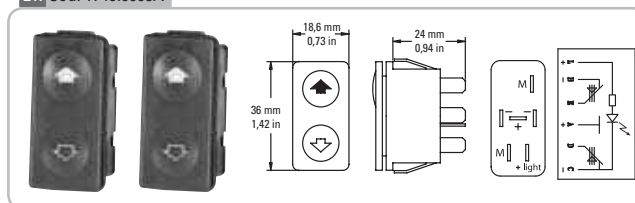

1 x Cod. 3303.0081

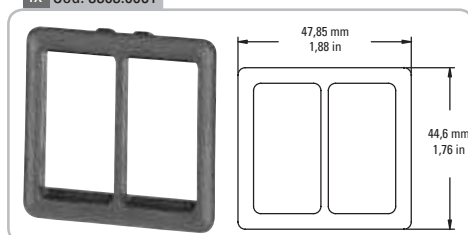

1 x Cod. 3302.0018





**KIT cod. 3304.0105**

- **KIT UNIVERSALE E RENAULT CLIO**  
completo di: 3 pulsanti Cod.1740.0090, 1 cornice singola Cod.3303.0071, 1 cornice doppia parallela Cod.3303.0070, 1 cornice doppia Cod.3303.0069, 1 cablaggio Cod.3302.0025.
- **KIT UNIVERSAL UND RENAULT CLIO**  
bestehend aus: 3 Schalter Cod.1740.0090, 1 Einzelrahmen Cod.3303.0071, 1 Doppelrahmen parallele Cod.3303.0070, 1 Doppelrahmen Cod.3303.0069, 1 Kabelsatz Cod.3302.0025.
- **KIT UNIVERSAL Y RENAULT CLIO**  
compuesto de: 3 pulsadores Cod.1740.0090, 1 soporte sencillo Cod.3303.0071, 1 soporte doble paralelo Cod.3303.0070, 1 soporte doble Cod.3303.0069, 1 cableado Cod.3302.0025.
- **KIT UNIVERSEL ET RENAULT CLIO**  
comprend: 3 interrupteurs Cod.1740.0090 1 support simple Cod.3303.0071, 1 support double parallèle Cod.3303.0070, 1 support double Cod.3303.0069, 1 câblage Cod.3302.0025.
- **KIT UNIVERSEEL EN RENAULT CLIO**  
bestaande uit: 3 schakelaars Cod.1740.0090, 1 Enkele frame Cod.3303.0071, 1 evenwijdig Dubbel frame Cod.3303.0070, 1 Dubbel frame Cod.3303.0069, 1 kabelset Cod.3302.0025.
- **KIT UNIVERSAL AND RENAULT CLIO**  
complete with: 3 switches Cod.1740.0090, 1 single frame Cod.3303.0071, 1 double frame parallel Cod.3303.0070, 1 double frame Cod.3303.0069, 1 wire harness Cod.3302.0025.
- **УНИВЕРСАЛЬНЫЙ И RENAULT CLIO КОМПЛЕКТ КНОПОК**  
комплектуется: 3 кнопками Cod.1740.0090, 1 односекционной рамкой Cod.3303.0071, 1 двухсекционной параллельной рамкой Cod.3303.0070, 1 двухсекционной рамкой Cod.3303.0069, 1 комплектом проводов Cod.3302.0025.
- **KIT UNIVERSAL E RENAULT CLIO**  
composto por: 3 botões Cód. 1740.0090, 1 moldura simples Cód. 3303.0071, 1 moldura dupla paralela Cód. 3303.0070, 1 moldura dupla Cód. 3303.0069, 1 chicote elétrico Cód. 3302.0025.
- **UNIVERZÁLIS ÉS RENAULT CLIO KÉSZLET**  
tartalma: 3 nyomógomb Cod. 1740.0090, 1 szimpla keret Cod. 3303.0071, 1 dupla párhuzamos keret Cod.3303.0070, 1 dupla keret Cod.3303.0069, 1 kábelköteg Cod.3302.0025.

3x Cod. 1740.0090

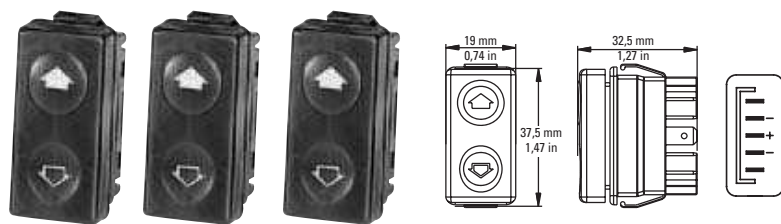

1x Cod. 3302.0025



1x Cod. 3303.0071

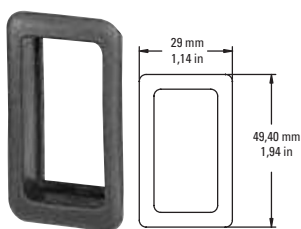

1x Cod. 3303.0070

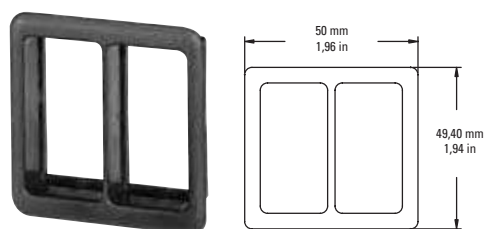

1x Cod. 3303.0069

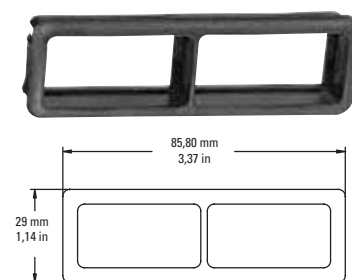



**KIT cod. 3304.0170**

- **KIT 7 PULSANTI UNIVERSALI USA PER BRACCIOLO**  
completo di: 7 pulsanti Cod.1740.0095A, 3 cornici singole Cod.3303.0079, 1 cornice Cod.3303.0100, 1 supporto Cod.3303.0099, 1 cablaggio Cod.3302.0017.
- **KIT 7 SCHALTER UNIVERSAL USA AUF ARMLEHNE**  
bestehend aus: 7 Schalter Cod.1740.0095A, 3 Einzelrahmen Cod.3303.0079, 1 Rahmen Cod.3303.0100, n.1 Schalterkonsole Cod.3303.0099, 1 Kabelsatz Cod.3302.0017.
- **KIT 7 PULSADORES UNIVERSAL USA PARA BRAZO DE PUERTA**  
compuesto de: 7 pulsadores Cod.1740.0095A, 3 soportes sencillo Cod.3303.0079, 1 soporte Cod.3303.0100, 1 soporte para pulsadores Cod.3303.0099, 1 cableado Cod.3302.0017.
- **KIT 7 INTERRUPTEURS UNIVERSELS USA POUR ACCOUDOIR**  
comprend: 7 interrupteurs Cod.1740.0095A, 3 supports simple Cod.3303.0079, 1 support Cod.3303.0100, 1 support pour interrupteurs Cod.3303.0099, 1 câblage Cod.3302.0017.
- **KIT 7 SCHAKELAARS UNIVERSEEL USA VOOR ARMSTEUN**  
bestaande uit: 7 schakelaars Cod.1740.0095A, 3 Enkele frames Cod.3303.0079, 1 frame Cod.3303.0100, 1 frame Cod.3303.0099, 1 kabelset Cod.3302.0017.
- **KIT 7 UNIVERSAL SWITCHES USA ON ARMREST**  
complete with: 7 switches Cod.1740.0095A, 3 single frames Cod.3303.0079, 1 frame Cod.3303.0100, 1 frame Cod.3303.0099, 1 wire harness Cod.3302.0017.
- **УНИВЕРСАЛЬНЫЙ КОМПЛЕКТ ИЗ 7 КНОПОК USA НА ПОДЛОКОННИК**  
комплектуются: 7 кнопками Cod.1740.0095A, 3 односекционными рамками Cod.3303.0079, 1 рамкой Cod.3303.0100, 1 рамкой Cod.3303.0099, 1 комплектом проводов Cod.3302.0017.
- **KIT DE 7 BOTÕES UNIVERSAIS U.S.A. PARA BRAÇO DA PORTA**  
composto por: 7 botões Cód. 1740.0095A, 3 molduras simples Cód. 3303.0079, 1 moldura Cód. 3303.0100, 1 suporte Cód. 3303.0099, 1 chicote elétrico Cód. 3302.0017.
- **7 NYOMÓGOMBOS UNIVERZÁLIS USA KÉSZLET KARTÁMSZHOZ**  
tartalma: 7 nyomógomb Cod. 1740.00905A, 3 szimpla keret Cod.3303.0079, keret Cod.3303.0100, 1 tartókonzol Cod.3303.0099, 1 kábelköteg Cod.3302.0017.

7 x Cod. 1740.0095A

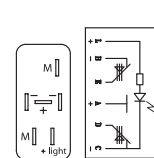
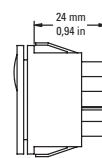
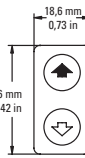

1 x Cod. 3302.0017



3 x Cod. 3303.0079

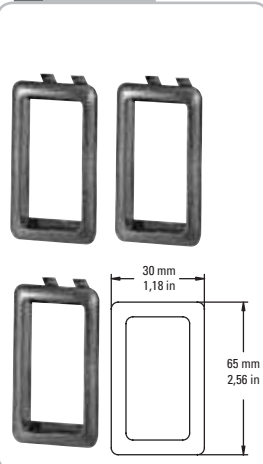

1 x Cod. 3303.0100

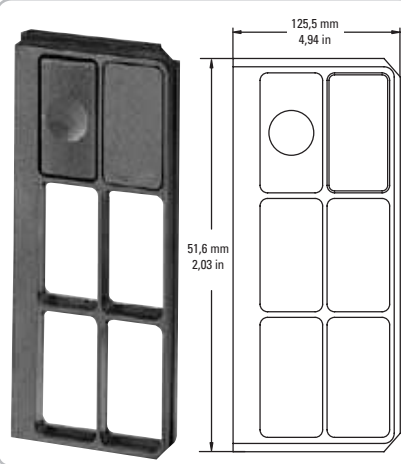

1 x Cod. 3303.0099

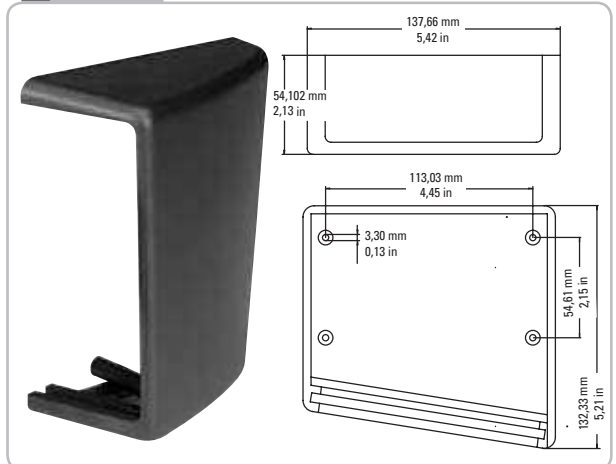

FRONT



FRONT



REAR



REAR

# KIT INTERRUTTORI

KIT SCHALTER • KIT PULSADORES • KIT INTERRUPTEURS • KIT SCHAKELAARS • SWITCH KIT • КОМПЛЕКТЫ КНОПОК СТЕКЛОПОДЪЕМНИКОВ • KIT DE INTERRUPTORES • KAPCSOLÓKÉSZLET



**KIT cod. 3304.0171**

**• KIT 7 PULSANTI UNIVERSALI USA SU PANNELLO**

completo di: 3 pulsanti Cod.1740.0099, 4 pulsanti Cod.1740.0094, 3 cornici singole Cod.3303.0024, 1 cornice Cod.3303.0100, 1 supporto Cod.3303.0099, 1 kit connettori per pulsanti 6 contatti Cod. 3304.0169, 1 cablaggio Cod.3302.0017.

**• KIT 7 SCHALTER UNIVERSAL USA AUF DER TÜRVERKEIDUNG**

bestehend aus: 3 Schalter Cod.1740.0099, 4 Schalter Cod.1740.0094, 3 Einzelrahmen Cod.3303.0024, 1 Rahmen Cod.3303.0100, 1 Schalterkonsole Cod.3303.0099, 1 Kit Schalterverbindungsstücken mit 6 Kontakten Cod. 3304.0169, 1 Kabelsatz Cod.3302.0017.

**• KIT 7 PULSADORES UNIVERSAL USA SOBRE PANEL**

compuesto de: 3 pulsadores Cod.1740.0099, 4 pulsadores Cod.1740.0094, 3 soportes sencillo Cod.3303.0024, 1 soporte Cod.3303.0100, 1 soporte para pulsantes Cod.3303.0099, 1 Kit Conectores para Interruptores 6 contactos Cod. 3304.0169, 1 cableado Cod.3302.0017.

**• KIT 7 INTERRUPTEURS UNIVERSELS USA POUR PANNEAU**

comprend: 3 interrupteurs Cod.1740.0099, 4 interrupteurs Cod.1740.0094, 3 supports simples Cod.3303.0024, 1 support Cod.3303.0100, 1 support pour interrupteurs Cod.3303.0099, 1 Kit Connecteurs pour interrupteurs à 6 contacts Cod. 3304.0169, 1 câblage Cod.3302.0017.

**• KIT 7 SCHAKELAARS UNIVERSEEL USA VOOR DEURPANEEL**

bestaande uit: 3 schakelaars Cod.1740.0099, 4 schakelaars Cod.1740.0094, 3 Enkele frames Cod.3303.0024, 1 frame Cod.3303.0100, 1 frame Cod.3303.0099, 1 kit connectoren voor zespolige schakelaars Cod. 3304.0169, 1 kabelset Cod.3302.0017.

**• KIT 7 UNIVERSAL SWITCHES USA ON DOOR CASING**

complete with: 3 switches Cod.1740.0099, 4 switches Cod.1740.0094, 3 single frames Cod.3303.0024, 1 frame Cod.3303.0100, 1 frame Cod.3303.0099, 1 kit 6-contacts switches connectors Cod. 3304.0169, 1 wire harness Cod.3302.0017.

**• УНИВЕРСАЛЬНЫЙ КОМПЛЕКТ ИЗ 7 КНОПОК USA НА ОБШИВКУ ДВЕРИ**

комплектуется: 3 кнопками Cod.1740.0099, 4 кнопками Cod.1740.0094, 3 односекционными рамками Cod.3303.0024, 1 рамкой Cod.3303.0100, 1 рамкой Cod.3303.0099, 6-контактные коннекторы кнопок Cod. 3304.0169, 1 комплектом проводов Cod.3302.0017.

**• KIT DE 7 BOTÕES UNIVERSAIS U.S.A. PARA PAINEL**

composto por: 3 botões Cód. 1740.0099, 4 botões Cód. 1740.0094, 3 molduras simples Cód. 3303.0024, 1 moldura Cód. 3303.0100, 1 suporte Cód. 3303.0099, 1 KIT conectores para botões de 6 contatos Cod. 3304.0169, 1 chicote elétrico Cód. 3302.0017.

**• 7 KAPCSOLÓS KÉSZLET USA KÉSZLET KÁRPITON**

Tartalom: 3 db 1740.0099 számú kapcsoló, 4 db 1740.0094 számú kapcsoló, 3 db szimpla keret cikkszám: 3303.0024, 1 db 3303.0100 számú keret, 1 db 3303.0099 számú keret, 1 db 6 pólusú csatlakozó aljzat db 3304.0169, 1 db 3302.0017 számú vezeték köteg.

3 x Cod. 1740.0099

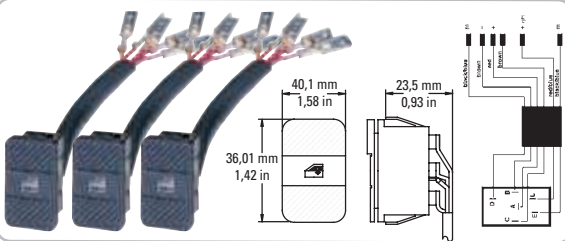

4 x Cod. 1740.0094

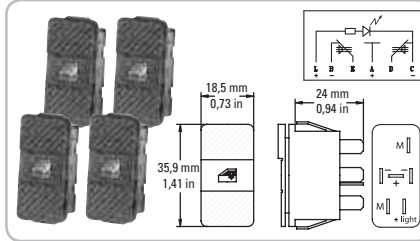

1 x Cod. 3304.0169

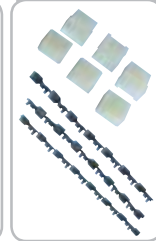

1 x Cod. 3302.0017



3 x Cod. 3303.0024

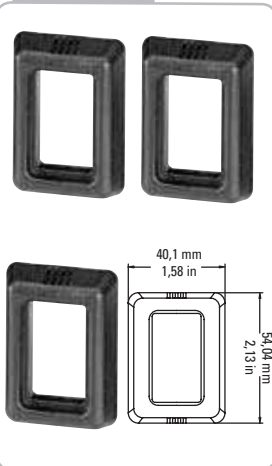

1 x Cod. 3303.0100

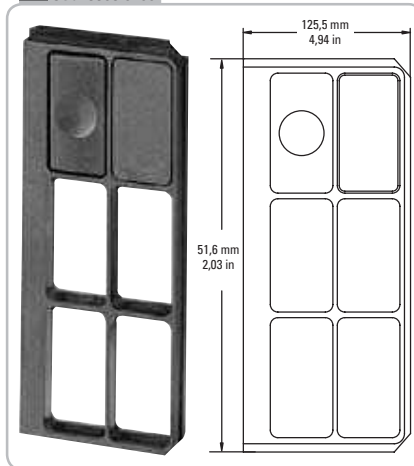

1 x Cod. 3303.0099

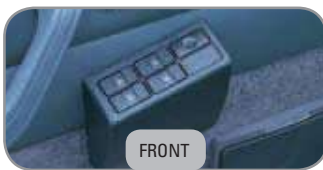
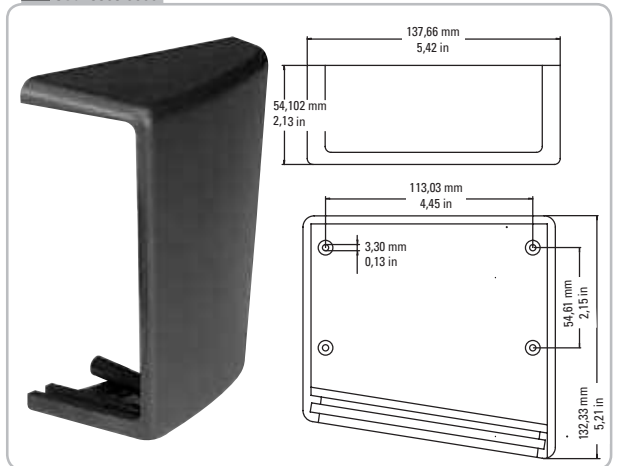

FRONT



FRONT

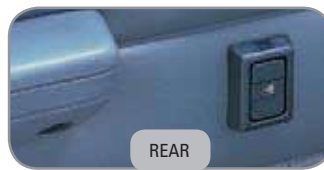

REAR



REAR



- **KIT 2 PULSANTI UNIVERSALI**  
completo di: 2 pulsanti Cod.1740.0007, 1 cablaggio Cod.3302.0001.
- **KIT 2 SCHALTER UNIVERSAL**  
bestehend aus: 2 Schalter Cod.1740.0007, 1 Kabelsatz Cod.3302.0001.
- **KIT 2 PULSADORES UNIVERSAL**  
compuesto de: 2 pulsadores Cod.1740.0007, 1 cableado Cod.3302.0001.
- **KIT 2 INTERRUPTEURS UNIVERSEL**  
comprend: 2 interrupteurs Cod.1740.0007, 1 câblage Cod.3302.0001.
- **KIT 2 SCHAKELAARS UNIVERSEEL**  
bestaande uit: 2 schakelaars Cod.1740.0007, 1 kabelset Cod.3302.0001.
- **KIT 2 UNIVERSAL SWITCHES**  
complete with: 2 switches Cod.1740.0007, 1 wire harness Cod.3302.0001.
- **УНИВЕРСАЛЬНЫЙ КОМПЛЕКТ ИЗ 2 КНОПОК**  
комплектуются: 2 кнопками Cod.1740.0007, 1 комплектом проводов Cod.3302.0001.
- **KIT DE 2 BOTÕES UNIVERSAIS**  
composto por: 2 botões Cód.1740.0007, 1 chicote elétrico Cód.3302.0001.
- **2 UNIVERZÁLIS NYOMÓGOMB KÉSZLET**  
tartalma: 2 nyomógomb Cod.1740.0007, 1 kábelköteg Cod.3302.0001.



**KIT cod. 3304.0018**

2 x Cod. 1740.0007

1 x Cod. 3302.0001

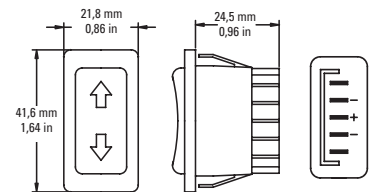

- **KIT 3 PULSANTI UNIVERSALI**  
completo di: 3 pulsanti Cod.1740.0007, 1 cablaggio Cod.3302.0029.
- **KIT 3 SCHALTER UNIVERSAL**  
bestehend aus: 3 Schalter Cod.1740.0007, 1 Kabelsatz Cod.3302.0029.
- **KIT 3 PULSADORES UNIVERSAL**  
compuesto de: 3 pulsadores Cod.1740.0007, 1 cableado Cod.3302.0029.
- **KIT 3 INTERRUPTEURS UNIVERSEL**  
comprend: 3 interrupteurs Cod.1740.0007, 1 câblage Cod.3302.0029.
- **KIT 3 SCHAKELAARS UNIVERSEEL**  
bestaande uit: 3 schakelaars Cod.1740.0007, 1 kabelset Cod.3302.0029.
- **KIT 3 UNIVERSAL SWITCHES**  
complete with: 3 switches Cod.1740.0007, 1 wire harness Cod.3302.0029.
- **УНИВЕРСАЛЬНЫЙ КОМПЛЕКТ ИЗ 3 КНОПОК В КОМПЛЕКТАЦИИ**  
комплектуются: 3 кнопками Cod.1740.0007, 1 комплектом проводов Cod.3302.0029.
- **KIT DE 3 BOTÕES UNIVERSAIS**  
composto por: 3 botões Cód.1740.0007, 1 chicote elétrico Cód.3302.0029.
- **3 UNIVERZÁLIS NYOMÓGOMB-KÉSZLET**  
tartalma: 3 nyomógomb Cod.1740.0007, 1 kábelköteg Cod.3302.0029.



**KIT cod. 3304.0126**

3 x Cod. 1740.0007

1 x Cod. 3302.0029

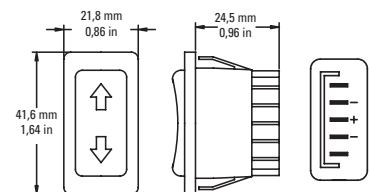

- **KIT UNIVERSALE DOPPIO CON SUPPORTO**  
2 pulsanti Cod.1740.0052, 1 supporto Cod.3303.0002, 1 cablaggio Cod.3302.0009.
- **KIT UNIVERSAL DOPPEL MIT GEHÄUSE**  
2 Schalter Cod.1740.0052, 1 Gehäuse Cod.3303.0002, 1 Kabelsatz Cod.3302.0009.
- **KIT UNIVERSAL DOBLE CON SOPORTE**  
2 pulsadores Cod.1740.0052, 1 soporte Cod.3303.0002, 1 cableado Cod.3302.0009.
- **KIT UNIVERSEL DOUBLE AVEC SUPPORT**  
2 interrupteurs Cod.1740.0052, 1 support Cod.3303.0002, 1 câblage Cod.3302.0009.
- **KIT UNIVERSEEL DUBBELE SCHAKELAAR MET OPBOUWKASTJE**  
2 schakelaars Cod.1740.0052, 1 opbouwkastje Cod.3303.0002, 1 kabelset Cod.3302.0009.
- **KIT UNIVERSAL DOUBLE WITH PANEL**  
2 switches Cod.1740.0052, 1 switch frame Cod.3303.0002, 1 wire harness Cod.3302.0009.
- **УНИВЕРСАЛЬНЫЙ КОМПЛЕКТ ИЗ 2 КНОПОК С ПАНЕЛЬЮ**  
2 кнопки Cod.1740.0052, 1 рамка-панель Cod.3303.0002, 1 комплект проводов Cod.3302.0009.
- **KIT UNIVERSAL DUPLO COM SUPORTE**  
2 botões Cód.1740.0052, 1 suporte Cód.3303.0002, 1 chicote elétrico Cód.3302.0009.
- **UNIVERZÁLIS DUPLA KÉSZLET TARTÓKONZOLLAL**  
2 nyomógomb Cod.1740.0052, 1 tartókonzol Cod.3303.0002, 1 kábelköteg Cod.3302.0009.



**KIT cod. 3304.0017**

1 x Cod. 3302.0009

2 x Cod. 1740.0052

1 x Cod. 3303.0002

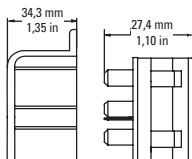
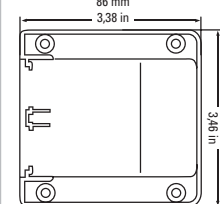
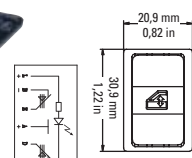

## KIT INTERRUTTORI

universal

KIT SCHALTER • KIT PULSADORES • KIT INTERRUPTEURS • KIT SCHAKELAARS • SWITCH KIT • КОМПЛЕКТЫ КНОПОК СТЕКЛОПОДЪЕМНИКОВ • KIT DE INTERRUPTORES • KAPCSOLÓKÉSZLET

### • KIT 2 PULSANTI UNIVERSALI

completo di: 2 pulsanti Cod.1740.0049, 1 cablaggio Cod.3302.0009.

### • KIT 2 SCHALTER UNIVERSAL

bestehend aus: 2 Schalter Cod.1740.0049, 1 Kabelsatz Cod.3302.0009.

### • KIT 2 PULSADORES UNIVERSAL

compuesto de: 2 pulsadores Cod.1740.0049, 1 cableado Cod.3302.0009.

### • KIT 2 INTERRUPTEURS UNIVERSEL

comprend: 2 interrupteurs Cod.1740.0049, 1 câblage Cod.3302.0009.

### • KIT 2 SCHAKELAARS UNIVERSEEL

bestaande uit: 2 schakelaars Cod.1740.0049, 1 kabelset Cod.3302.0009.

### • KIT 2 UNIVERSAL SWITCHES

complete with: 2 switches Cod.1740.0049, 1 wire harness Cod.3302.0009.

### • УНИВЕРСАЛЬНЫЙ КОМПЛЕКТ ИЗ 2 КНОПОК

комплектуется: 2 кнопками Cod.1740.0049, 1 комплектом проводов Cod.3302.0009.

### • KIT DE 2 BOTÕES UNIVERSAIS

composto por: 2 botões Cód.1740.0049, 1 chicote elétrico Cód.3302.0009.

### • 2 UNIVERZÁLIS NYOMÓGOMB KÉSZLET

tartalma: 2 nyomógomb Cod. 1740.0049, 1 kábelköteg Cod. 3302.0009.



KIT cod. 3304.0041

2 x Cod. 1740.0049

1 x Cod. 3302.0009

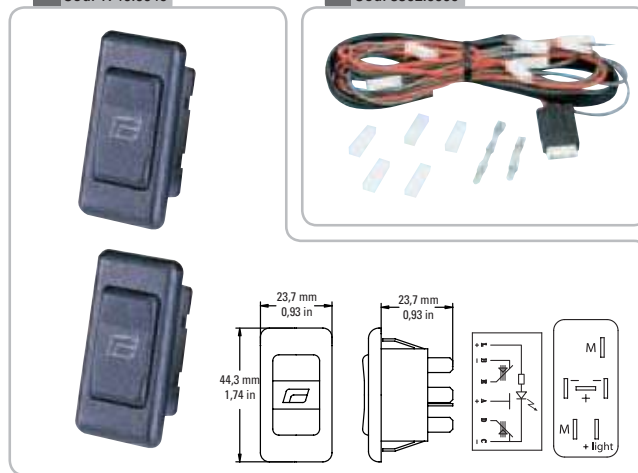

### • KIT 3 PULSANTI UNIVERSALI "VERSIONE LUSO"

completo di: 3 pulsanti Cod.1740.0049, 1 cablaggio Cod.3302.0022.

### • KIT 3 SCHALTER UNIVERSAL "MOD. LUXUS"

bestehend aus: 3 Schalter Cod.1740.0049, 1 Kabelsatz Cod.3302.0022.

### • KIT 3 PULSADORES UNIVERSAL "VERSIÓN LUJO"

compuesto de: 3 pulsadores Cod.1740.0049, 1 cableado Cod.3302.0022.

### • KIT 3 INTERRUPTEURS UNIVERSEL "VERSION LUXE"

comprend: 3 interrupteurs Cod.1740.0049, 1 câblage Cod. 3302.0022.

### • KIT 3 SCHAKELAARS UNIVERSEEL "LUXE VITVOERING"

bestaande uit: 3 schakelaars Cod.1740.0049, 1 kabelset Cod.3302.0022.

### • KIT 3 UNIVERSAL SWITCHES "LUXE VERSION"

complete with: 3 switches Cod.1740.0049, 1 wire harness Cod.3302.0022.

### • УНИВЕРСАЛЬНЫЙ КОМПЛЕКТ ИЗ 3 КНОПОК В КОМПЛЕКТАЦИИ "ЛЮКС"

комплектуется: 3 кнопками Cod.1740.0049, 1 комплектом проводов Cod.3302.0022.

### • KIT DE 3 BOTÕES UNIVERSAIS "VERSÃO LUXO"

composto por: 3 botões Cód.1740.0049, 1 chicote elétrico Cód.3302.0022.

### • 3 UNIVERZÁLIS NYOMÓGOMB KÉSZLET "LUXUS VÁLTOZAT"

tartalma: 3 nyomógomb Cod.1740.0049, 1 kábelköteg Cod.3302.0022.



KIT cod. 3304.0127

3 x Cod. 1740.0049

1 x Cod. 3302.0022





**KIT cod. 3304.0128**

- **KIT UNIVERSALE CON CORNICI**  
completo di: 3 pulsanti Cod. 1740.0099, 1 cornice singola Cod. 3303.0024, 1 cornice doppia Cod. 3303.0025, 1 cablaggio Cod. 3302.0032.
- **KIT UNIVERSAL MIT RAHMEN**  
bestehend aus: 3 Schalter Cod.1740.0099, 1 Einzelrahmen Cod.3303.0024, 1 Doppelrahmen Cod.3303.0025, 1 Kabelsatz Cod.3302.0032.
- **KIT UNIVERSAL CON SOPORTES**  
compuesto de: 3 pulsadores Cod.1740.0099, 1 soporte sencillo Cod.3303.0024, 1 soporte doble Cod.3303.0025, 1 cableado Cod.3302.0032.
- **KIT UNIVERSEL AVEC SUPPORTS**  
comprend: 3 interrupteurs Cod.1740.0099, 1 support simple Cod.3303.0024, 1 support double Cod.3303.0025, 1 câblage Cod.3302.0032.
- **KIT UNIVERSEEL MET FRAMES**  
bestaande uit: 3 schakelaars Cod.1740.0099, 1 Enkele frame Cod.3303.0024, 1 Dubbel frame Cod.3303.0025, 1 kabelset Cod.3302.0032.
- **KIT UNIVERSAL WITH FRAMES**  
complete with: 3 switches Cod.1740.0099, 1 single frame Cod.3303.0024, 1 double frame Cod.3303.0025, 1 wire harness Cod.3302.0032.
- **УНИВЕРСАЛЬНЫЙ КОМПЛЕКТ КНОПОК С РАМКАМИ**  
комплектуется: 3 кнопками Cod.1740.0099, 1 односекционной рамкой Cod.3303.0024, 1 двухсекционной рамкой Cod.3303.0025, 1 комплектом проводов Cod.3302.0032.
- **KIT UNIVERSAL COM MOLDURAS**  
composto por: 3 botões Cód. 1740.0099, 1 moldura simples Cód. 3303.0024, 1 moldura dupla Cód. 3303.0025, 1 chicote elétrico Cód. 3302.0032.
- **UNIVERZÁLIS KÉSZLET KERETEKEL**  
tartalma: 3 nyomógomb Cod. 1740.0099, 1 szimpla keret Cod. 3303.0024, 1 dupla keret Cod. 3303.0025, 1 kábelköteg Cod. 3302.0032.

3 x Cod. 1740.0099

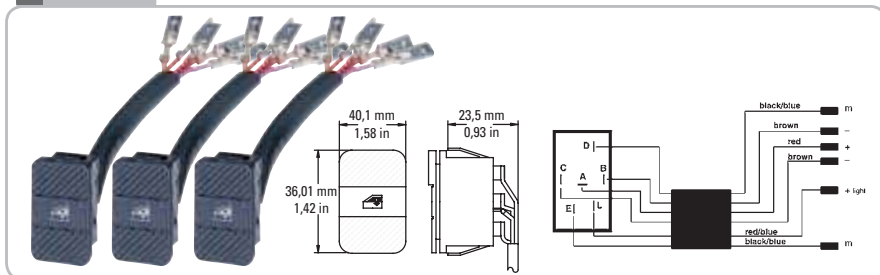

1 x Cod. 3302.0032



1 x Cod. 3303.0024

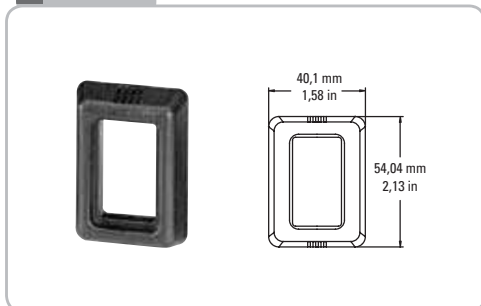

1 x Cod. 3303.0025

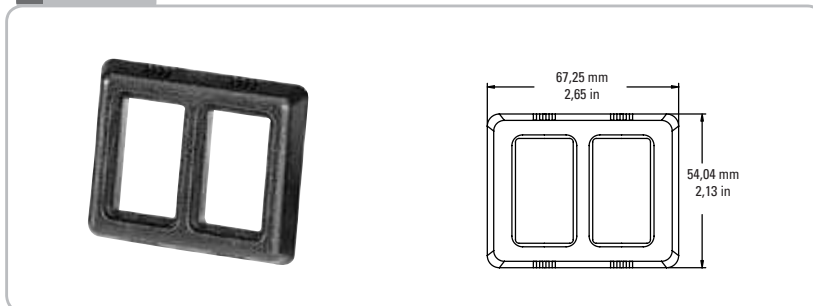

## KIT INTERRUUTORI

BMW • Mercedes • Opel

KIT SCHALTER • KIT PULSADORES • KIT INTERRUPTEURS • KIT SCHAKELAARS • SWITCH KIT • КОМПЛЕКТЫ КНОПОК СТЕКЛОПОДЪЕМНИКОВ • KIT DE INTERRUPTORES • KAPCSOLÓKÉSZLET

• **KIT 2 BMW SERIE 3 MOD. '87**  
completo di: 2 pulsanti Cod.1740.0010, 1 cablaggio Cod.3302.0001.

• **KIT 2 BMW SERIE 3 MOD. '87**  
bestehend aus: 2 Schalter Cod.1740.0010, 1 Kabelsatz Cod.3302.0001.

• **KIT 2 BMW SERIE 3 MOD. '87**  
compuesto de: 2 pulsadores Cod.1740.0010, 1 cableado Cod.3302.0001.

• **KIT 2 BMW SERIE 3 MOD. '87**  
comprend: 2 interrupteurs Cod.1740.0010, 1 câblage Cod.3302.0001.

• **KIT 2 BMW SERIE 3 MOD. '87**  
bestaande uit: 2 schakelaars Cod.1740.0010, 1 kabelset Cod.3302.0001.

• **KIT 2 BMW SERIE 3 MOD. '87**  
complete with: 2 switches Cod.1740.0010, 1 wire harness Cod.3302.0001.

• **КОМПЛЕКТ ИЗ 2 КНОПОК BMW SERIE 3 MOD:'87**  
комплектуется: 2 кнопками Cod.1740.0010, 1 комплектом проводов Cod.3302.0001.

• **KIT BMW SÉRIE 3 MOD. '87**  
composto por: 2 botões Cód. 1740.0010, 1 chicote elétrico Cód. 3302.0001.

• **2 BMW 3 SZÉRIA MOD. '87 KÉSZLET**  
tartalma: 2 nyomógomb Cod.1740.0010, 1 kábelköteg Cod.3302.0001.



**KIT cod. 3304.0030**

2 x Cod. 1740.0010

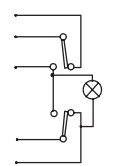
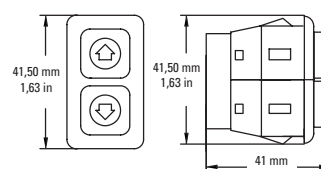

1 x Cod. 3302.0001



• **KIT 2 PULSANTI MERCEDES 190-200 MOD. '88**  
completo di: 2 pulsanti Cod.1740.0061A, 1 cablaggio Cod.3302.0009.

• **KIT 2 SCHALTER MERCEDES 190-200 MOD. '88**  
bestehend aus: 2 Schalter Cod.1740.0061A, 1 Kabelsatz Cod.3302.0009.

• **KIT 2 PULSADORES MERCEDES 190-200 MOD. '88**  
compuesto de: 2 pulsadores Cod.1740.0061A, 1 cableado Cod.3302.0009.

• **KIT 2 INTERRUPTEURS MERCEDES 190-200 MOD. '88**  
comprend: 2 interrupteurs Cod.1740.0061A, 1 câblage Cod.3302.0009.

• **KIT MERCEDES 190-200 MOD. '88 SCHAKELAARS**  
bestaande uit: 2 schakelaars Cod.1740.0061A, 1 kabelset Cod.3302.0009.

• **KIT MERCEDES 190-200 MOD. '88 SWITCHES**  
complete with: 2 switches Cod.1740.0061A, 1 wire harness Cod.3302.0009.

• **КОМПЛЕКТ КНОПОК MERCEDES 190-200 MOD:'88**  
комплектуется: 2 кнопками Cod.1740.0061A, 1 комплектом проводов Cod.3302.0009.

• **KIT DE 2 BOTÕES MERCEDES 190-200 MOD. '88**  
composto por: 2 botões Cód. 1740.0061A, 1 chicote elétrico Cód.3302.0009.

• **2 NYOMÓGOMB KÉSZLET MERCEDES 190-200 MOD. '88**  
tartalma: 2 nyomógomb Cod.1740.0061A, 1 kábelköteg Cod.3302.0009.



**KIT cod. 3304.0049**

2 x Cod. 1740.0061A

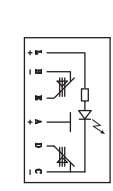
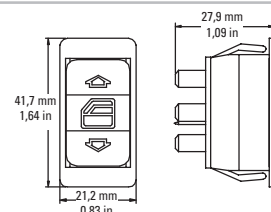

1 x Cod. 3302.0009



• **KIT 2 PULSANTI OPEL OMEGA / VECTRA**  
completo di: 2 pulsanti Cod.1740.0068, 1 cablaggio Cod.3302.0009.

• **KIT 2 SCHALTER OPEL OMEGA / VECTRA**  
bestehend aus: 2 Schalter Cod.1740.0068, 1 Kabelsatz Cod.3302.0009.

• **KIT 2 PULSADORES OPEL OMEGA / VECTRA**  
compuesto de: 2 pulsadores Cod.1740.0068, 1 cableado Cod.3302.0009.

• **KIT 2 INTERRUPTEURS OPEL OMEGA / VECTRA**  
comprend: 2 interrupteurs Cod.1740.0068, 1 câblage Cod.3302.0009.

• **KIT OPEL OMEGA / VECTRA SCHAKELAARS**  
bestaande uit: 2 schakelaars Cod.1740.0068, 1 kabelset Cod.3302.0009.

• **KIT OPEL OMEGA / VECTRA SWITCHES**  
complete with: 2 switches Cod.1740.0068, 1 wire harness Cod.3302.0009.

• **КОМПЛЕКТ КНОПОК OPEL OMEGA / VECTRA**  
комплектуется: 2 кнопками Cod.1740.0068, 1 комплектом проводов Cod.3302.0009.

• **KIT DE 2 BOTÕES OPEL OMEGA / VECTRA**  
composto por: 2 botões Cód. 1740.0068, 1 chicote elétrico Cód. 3302.0009.

• **2 NYOMÓGOMB KÉSZLET OPEL OMEGA / VECTRA**  
tartalma: 2 nyomógomb Cod.1740.0068, 1 kábelköteg Cod.3302.0009.



**KIT cod. 3304.0056**

2 x Cod. 1740.0068

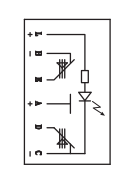
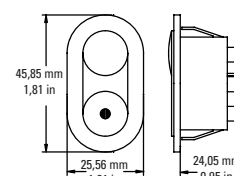

1 x Cod. 3302.0009





KIT cod. 3304.0140

- **KIT OPEL CORSA MOD.'93 SU TUNNEL**  
completo di: 2 pulsanti Cod. 1740.0103, 1 supporto Cod. 3303.0091, 1 cablaggio Cod. 3302.0018.
- **KIT OPEL CORSA MOD.'93 AUF TUNNEL**  
bestehend aus: 2 Schalter Cod.1740.0103, 1 Schalterkonsole Cod.3303.0091, 1 Kabelsatz Cod.3302.0018.
- **KIT OPEL CORSA MOD.'93 SOBRE TUNNEL**  
compuesto de: 2 pulsadores Cod.1740.0103, 1 soporte Cod.3303.0091, 1 cableado Cod.3302.0018.
- **KIT OPEL CORSA MOD.'93 SUR TUNNEL**  
comprend: 2 interrupteurs Cod.1740.0103, 1 support Cod.3303.0091, 1 câblage Cod.3302.0018.
- **KIT OPEL CORSA MOD.'93 OP TUNNEL**  
bestaande uit: 2 schakelaars Cod.1740.0103, 1 frame Cod.3303.0091, 1 kabelset Cod.3302.0018.
- **KIT OPEL CORSA MOD.'93 ON TUNNEL**  
complete with: 2 switches Cod.1740.0103, 1 frame Cod.3303.0091, 1 wire harness Cod.3302.0018.
- **КОМПЛЕКТ КНОПОК OPEL CORSA MOD.'93 НА КОРОБКУ ПЕРЕДАЧ**  
комплектуется: 2 кнопками Cod.1740.0103, 1 рамкой Cod.3303.0091, 1 комплектом проводов Cod.3302.0018.
- **KIT OPEL CORSA MOD. 93 EM TÚNEL**  
composto por: 2 botões Cód. 1740.0103, 1 suporte Cód. 3303.0091, 1 chicote elétrico Cód. 3302.0018.
- **OPEL CORSA MOD.'93 KÉSZLET ELSŐ AJTÓHOZ**  
tartalma: 2 nyomógomb Cod. 1740.0103, 1 tartókonzol Cod.3303.0091, 1 kábelköteg Cod. 3302.0018.

2x Cod. 1740.0103

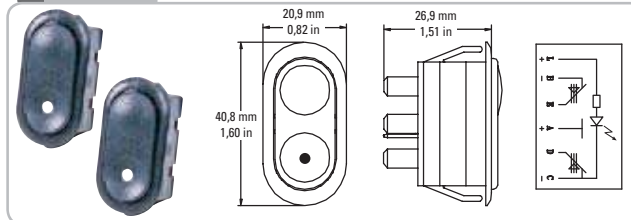

1x Cod. 3303.0091

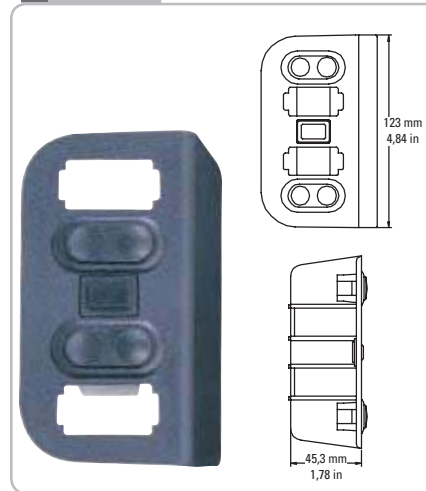

1x Cod. 3302.0018



KIT cod. 3304.0141

- **KIT OPEL CORSA MOD.'93 POSTERIORE**  
completo di: 2 pulsanti Cod. 1740.0103, di 2 pulsanti Cod. 1740.00085, 1 blocco Cod. 1740.0073, 1 cablaggio Cod. 3302.0020.
- **KIT OPEL CORSA MOD.'93 HINTEN**  
bestehend aus: 2 Schalter Cod. 1740.0103, 2 Schalter Cod. 1740.0085, 1 Sperrschalter Cod. 1740.0073, 1 Kabelsatz Cod.3302.0020.
- **KIT OPEL CORSA MOD.'93 POSTERIOR**  
compuesto de: 2 pulsadores Cod. 1740.0103, 2 pulsadores Cod.1740.0085, 1 bloqueo Cod. 1740.0073, 1 cableado Cod.3302.0020.
- **KIT OPEL CORSA MOD.'93 ARRIERE**  
comprend: 2 interrupteurs Cod. 1740.0103, 2 interrupteurs Cod.1740.0085, 1 bloc Cod. 1740.0073, 1 câblage Cod.3302.0020.
- **KIT OPEL CORSA MOD.'93 ACHTER**  
bestaande uit: 2 schakelaars Cod.1740.0103, 2 schakelaars Cod.1740.0085, 1 blokkering Cod. 1740.0073, 1 kabelset Cod.3302.0020.
- **KIT OPEL CORSA MOD.'93 REAR**  
complete with: 2 switches Cod.1740.0103, 1 switches Cod.1740.0085, 1 rear isolator switch Cod. 1740.0073, 1 wire harness Cod.3302.0020.
- **КОМПЛЕКТ КНОПОК ПЕРЕДНИХ И ЗАДНИХ СТЕКОЛ OPEL CORSA MOD.'93 НА КОРОБКУ ПЕРЕДАЧ**  
комплектуется: 2 кнопками Cod.1740.0103, 2 кнопками Cod.1740.0085, 1 кнопкой блокировки Cod.1740.0073, 1 комплектом проводов Cod.3302.0020.
- **KIT OPEL CORSA MOD. 93 TRASEIRO**  
composto por: 2 botões Cód. 1740.0103, 2 botões Cód. 1740.0085, 1 bloco Cód. 1740.0073, 1 chicote elétrico Cód. 3302.0020.
- **OPEL CORSA MOD.'93 KÉSZLET HÁTSÓ AJTÓHOZ**  
tartalma: 2 nyomógomb Cod. 1740.0103, 2 nyomógomb Cod. 1740.00085, 1 blokk Cod. 1740.0073, 1 kábelköteg Cod. 3302.0020.

2x Cod. 1740.0085

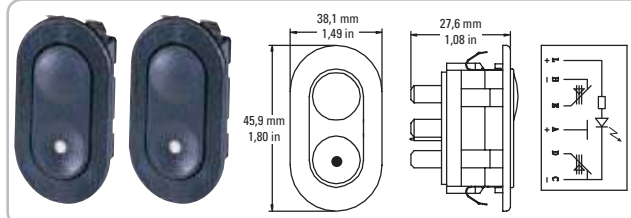

2x Cod. 1740.0103

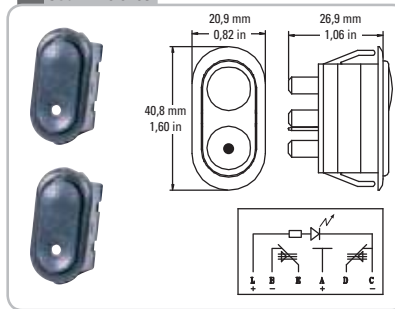

1x Cod. 1740.0073

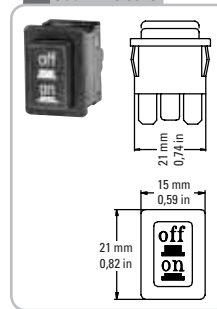

1x Cod. 3302.0020



NEW

# KIT INTERRUITORI

universal push & pull

KIT SCHALTER • KIT PULSADORES • KIT INTERRUPTEURS • KIT SCHAKELAARS • SWITCH KIT • КОМПЛЕКТЫ КНОПОК СТЕКЛОПОДЪЕМНИКОВ • KIT DE INTERRUPTORES • KAPCSOLÓKÉSZLET



**KIT cod. 3304.0262**

**• KIT 7 PULSANTI UNIVERSALI**

completo di: 7 pulsanti Cod.1740.0110A, 3 cornici singole e 3 supporti Cod.3303.0170, 1 cornice e 2 pulsanti Cod.3303.0168, 1 supporto Cod.3303.0099, 1 supporto in metallo Cod. 3303.0171, 3 supporti in metallo Cod. 3303.0172, 1 cablaggio Cod.3302.0040, 1 cablaggio Cod.3302.0041.

**• KIT 7 SCHALTER UNIVERSAL**

bestehend aus : 7 Schaltern Code 1740.0110A, 3 Einzelrahmen und 3 Schalterkonsolen Code 3303.0170, 1 Rahmen mit 2 Schaltern Code 3303.0168, 1 Schalterkonsole Code 3303.0099, 1 Metall-Halterung Code 3303.0171, 3 Metall-Halterungen Code 3303.0172, 1 Kabelsatz Code 3302.0040, 1 Kabelsatz Code 3302.0041.

**• KIT 7 PULSADORES UNIVERSAL**

compuesto de : 7 pulsadores Cód.1740.0110A, 3 soportes simples y 3 soportes Cód. 3303.0170, 1 marco y 2 pulsadores Cód.3303.0168, 1 soporte Cód. 3303.0099, 1 soporte metálico Cód. 3303.0171, 3 soportes metálicos Cód.3303.0172, 1 cableado Cód.3302.0040, 1 cableado Cód.3302.0041.

**• KIT 7 INTERRUPTEURS UNIVERSELS**

comprend : 7 interrupteurs Code 1740.0110A, 3 supports simples et 3 supports Cod.3303.0170, 1 support et 2 interrupteurs Code 3303.0168, 1 support Code 3303.0099, 1 support en métal Code 3303.0171, 3 supports en métal Code 3303.0172, 1 câblage Code 3302.0040, 1 câblage Code 3302.0041.

**• KIT 7 SCHAKELAARS UNIVERSEEL**

bestaande uit : 7 schakelaars Code 1740.0110A, 3 Enkele frames en 3 steunen Code 3303.0170, 1 frame en 2 schakelaars Code 3303.0168, 1 frame Code 3303.0099, 1 metalen steun Code 3303.0171, 3 metalen steunen Code 3303.0172, 1 kabelset Code 3302.0040, 1 kabelset Code 3302.0041.

**• KIT 7 UNIVERSAL SWITCHES**

complete with : 7 switches Code 1740.0110A, 3 single frames with 3 supports Code 3303.0170, 1 frame with 2 switches Code 3303.0168, 1 metal bracket Code 3303.0171, 3 metal brackets Code 3303.0172, 1 wiring harness Code 3302.0040, 1 wiring harness Code 3302.0041.

**• УНИВЕРСАЛЬНЫЙ КОМПЛЕКТ ИЗ 7 КНОПОК**

В комплект поставки входят: 7 кнопок код 1740.0110A, 3 одинарные рамки и 3 суппорта код 3303.0170, 1 рамка и 2 кнопки код 3303.0168, 1 суппорт код 3303.0099, 1 металлический суппорт код 3303.0171, 3 металлических суппорта код 3303.0172, 1 комплект электропроводки код 3302.0040, 1 комплект электропроводки код 3302.0041.

**• KIT DE 7 BOTÕES UNIVERSAIS**

composto por: 7 botões Cód.1740.0110A, 3 molduras simples e 3 suportes Cód.3303.0170, 1 moldura e 2 botões Cód.3303.0168, 1 suporte Cód.3303.0099, 1 suporte de metal Cód.3303.0171, 3 suportes de metal Cód.3303.0172, 1 chicote elétrico Cód.3302.0040, 1 chicote elétrico Cód.3302.0041.

**• 7 KAPCSOLÓS KÉSZLET**

tartalma : 7 db Cod.1740.0110A számú nyomógomb, 3 db Cod.3303.0170 számú szimpla keret és 3 tartókeret, 1 db Cod.3303.0168 számú keret és 2 db nyomógomb, 1 db Cod.3303.0099 számú keret, 1 db Cod.3303.0171 számú fém tartó, 3 db Cod.3303.0172 számú fém tartó, 1 db 3302.0040 számú vezeték köteg, 1 db 3302.0041 számú vezeték köteg.

7 x Cod. 1740.0110A



1 x Cod. 3302.0040



1 x Cod. 3302.0041



3 x Cod. 3303.0170



1 x Cod. 3303.0099

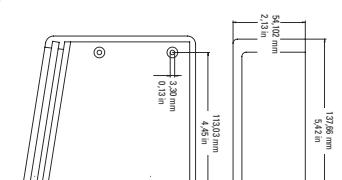

1 x Cod. 3303.0168



3 x Cod. 3303.0172

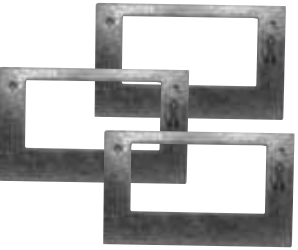

1 x Cod. 3303.0171

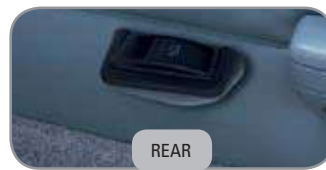
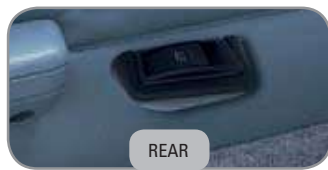

**LED GREEN** **12V** **cod. 1740.0048**

**universal**

- 6 contatti con luce separata
- 6 Kontakte mit getrennte Beleuchtung
- 6 contactos luces separadas
- 6 contacts avec éclairage séparé
- 6 contacten gescheiden aansluiting voor verlichting
- 6 contacts with separated light



23,8 mm 0,94 in  
27,7 mm 1,09 in  
44,4 mm 1,75 in

**LED GREEN** **12V** **cod. 1740.0050**

**Seat Toledo**  
**VW Golf Jetta serie II mod. '84/87 - Polo mod. '94**

- 6 contatti con luce separata
- 6 Kontakte mit getrennte Beleuchtung
- 6 contactos luces separadas
- 6 contacts avec éclairage séparé
- 6 contacten gescheiden aansluiting voor verlichting
- 6 contacts with separated light



23,8 mm 0,93 in  
27,9 mm 1,09 in  
39,8 mm 1,56 in

**LED GREEN** **12V** **cod. 1740.0083A**

**Ford Escort Orion • Skoda Favorit forman - Felicia mod. '94**

- 6 contatti con luce separata
- 6 Kontakte mit getrennte Beleuchtung
- 6 contactos luces separadas
- 6 contacts avec éclairage séparé
- 6 contacten gescheiden aansluiting voor verlichting
- 6 contacts with separated light



20,9 mm 0,82 in  
26,9 mm 1,06 in  
40,6 mm 1,59 in

**LED YELLOW** **12V** **cod. 1740.0085**

**Opel Astra mod. '98**

- 6 contatti con luce separata
- 6 Kontakte mit getrennte Beleuchtung
- 6 contactos luces separadas
- 6 contacts avec éclairage séparé
- 6 contacten gescheiden aansluiting voor verlichting
- 6 contacts with separated light





38,1 mm 1,49 in  
27,6 mm 1,08 in  
45,9 mm 1,80 in

**LED RED** **12V** **cod. 1740.0088**

**Seat Ibiza - Cordoba mod. '93**

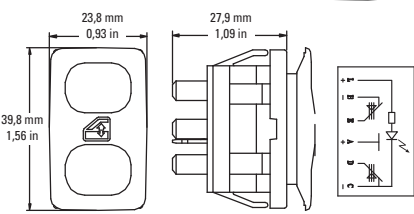
- 6 contatti con luce separata
- 6 Kontakte mit getrennte Beleuchtung
- 6 contactos luces separadas
- 6 contacts avec éclairage séparé
- 6 contacten gescheiden aansluiting voor verlichting
- 6 contacts with separated light





23,8 mm 0,93 in  
27,9 mm 1,09 in  
39,8 mm 1,56 in

**LED GREEN** **12V** **cod. 1740.0091A**

**Fiat Punto mod. '94 - Palio**

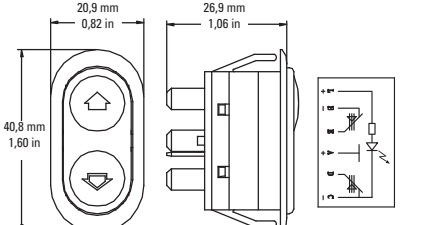
- 6 contatti con luce separata
- 6 Kontakte mit getrennte Beleuchtung
- 6 contactos luces separadas
- 6 contacts avec éclairage séparé
- 6 contacten gescheiden aansluiting voor verlichting
- 6 contacts with separated light





20,9 mm 0,82 in  
26,9 mm 1,06 in  
40,8 mm 1,60 in

**LED GREEN** **12V** **cod. 1740.0092A**

**Citroën Xsara Picasso • Fiat Punto mod. '94 - Palio**  
**Ford Escort Orion • Skoda Favorit forman - Felicia mod. '94**

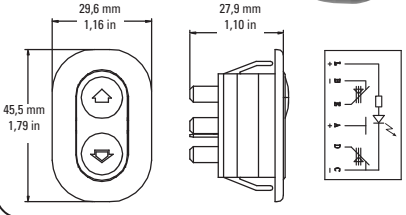
- 6 contatti con luce separata
- 6 Kontakte mit getrennte Beleuchtung
- 6 contactos luces separadas
- 6 contacts avec éclairage séparé
- 6 contacten gescheiden aansluiting voor verlichting
- 6 contacts with separated light





29,6 mm 1,16 in  
27,9 mm 1,10 in  
45,5 mm 1,79 in

**LED GREEN** **12V** **cod. 1740.0094**

**Universal • Hyundai Lantra mod. '96**  
**VW Golf Vento mod. '96**

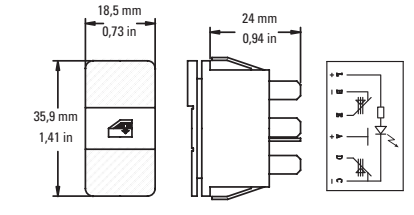
- 6 contatti con luce separata
- 6 Kontakte mit getrennte Beleuchtung
- 6 contactos luces separadas
- 6 contacts avec éclairage séparé
- 6 contacten gescheiden aansluiting voor verlichting
- 6 contacts with separated light

18,5 mm 0,73 in  
24 mm 0,94 in  
35,9 mm 1,41 in

**LED YELLOW** **12V** **cod. 1740.0125**

**Opel Astra mod. '98**

- 6 contatti con luce separata
- 6 Kontakte mit getrennte Beleuchtung
- 6 contactos luces separadas
- 6 contacts avec éclairage séparé
- 6 contacten gescheiden aansluiting voor verlichting
- 6 contacts with separated light



26,2 mm 1,03 in  
36,2 mm 1,03 in

# INTERRUTTORI ED ACCESSORI

SCHALTER UND ZUBEHÖR • PULSADORES Y ACCESORIOS • INTERRUPTEURS ET ACCESSOIRES • SCHAKELAARS EN ACCESSORIES • SWITCH AND OPTIONAL ACCESSORIES • КНОПКИ И ДОПОЛНИТЕЛЬНЫЕ АКЦЕССУАРЫ • INTERRUPTORES E ACESSÓRIOS • KAPCSOLÓK ÉS KIEGÉSZÍTŐK

**LED GREEN** **12V** **cod. 1740.0128A**

**Citröen Xsara Picasso • Fiat Punto mod. 94 - Palio  
Ford Escort Orion • Skoda Fabia 2000**

- 6 contatti con luce separata
- 6 Kontakte mit getrennte Beleuchtung
- 6 contactos luces separadas
- 6 contacts avec éclairage séparé
- 6 contacten gescheiden aansluiting voor verlichting
- 6 contacts with separated light

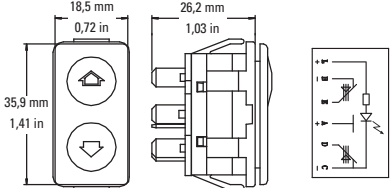
**cod. 3304.0079**

**Kit Relé 12V - 15/30 Amp.**

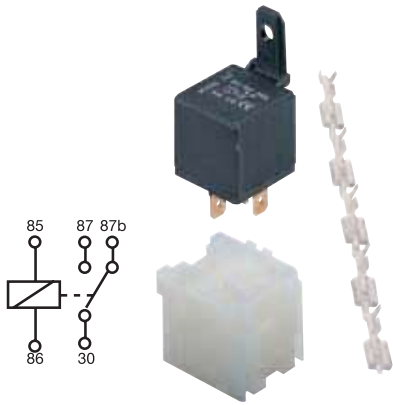

85 87 87b  
86 30

PACKING 50 PCS.

**cod. 1795.0025**

**Kit Relé 12V - 15/30 Amp.**

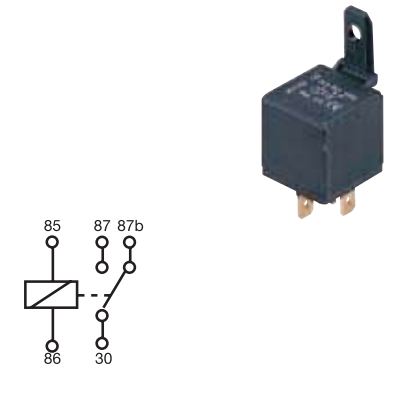

85 87 87b  
86 30

PACKING 20 PCS.

**cod. 3304.0059**

- Connettore per pulsanti 6 contatti
- Stecker mit 6 Kontakten
- Connector para pulsadores de 6 contactos
- Connecteur pour interrupteur à 6 contacts
- Connector voor 6-contacten schakelaar
- 6-contacts switches connector



PACKING 10 PCS.

**cod. 3304.0111**

- Connettore per pulsanti 5 contatti
- Stecker mit 5 Kontakten
- Connector para pulsadores de 5 contactos
- Connecteur pour interrupteur à 5 contacts
- Connector voor 5-contacten schakelaar
- 5-contacts switches connector



PACKING 10 PCS.

**cod. 3304.0150**

- Connettore per pulsanti 6 contatti
- Stecker mit 6 Kontakten
- Connector para pulsadores de 6 contactos
- Connecteur pour interrupteur à 6 contacts
- Connector voor 6-contacten schakelaar
- 6-contacts switches connector



PACKING 10 PCS.

**cod. 3301.0058**

- Maniglia di emergenza
- Nothandkurbel
- Manivela de emergencia
- Manivelle de secours
- Noodhendel
- Emergency handle



PACKING 10 PCS.

**cod. 3301.0092**

- Rondella
- Unterlegscheibe
- Arandela
- Rondelle
- Afwerkingsring
- Round washer



**cod. 3301.0143**

**Kit 2-4**

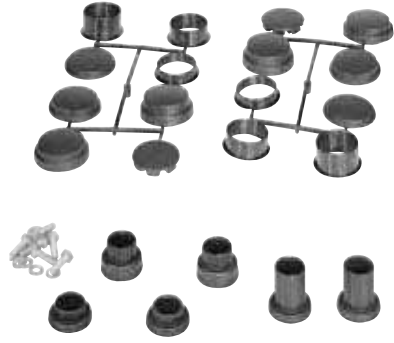



# INTERRUTTORI ED ACCESSORI

SCHALTER UND ZUBEHÖR • PULSADORES Y ACCESORIOS • INTERRUPTEURS ET ACCESSOIRES • SCHAKELAARS EN ACCESSORIES • SWITCH AND OPTIONAL ACCESSORIES • КНОПКИ И ДОПОЛНИТЕЛЬНЫЕ АКССУАРЫ • INTERRUPTORES E ACESSÓRIOS • KAPCSOLÓK ÉS KIEGÉSZÍTŐK

cod. 3301.0144

Kit 1-5



cod. 3301.0155

Kit 3

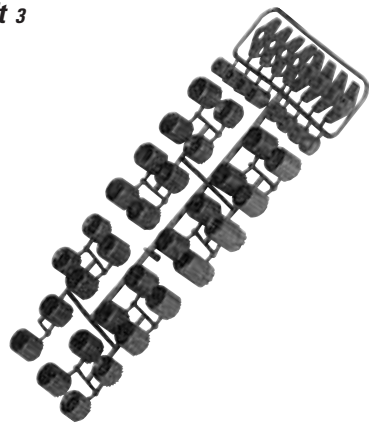

cod. 3301.0027



12v cod. 3301.0133 24v cod. 3301.0135

• "A" side



12v cod. 3301.0134 24v cod. 3301.0136

• "B" side



12v cod. 3301.0137

• Deluxe "A" side



12v cod. 3301.0138

• Deluxe "B" side



# CABLAGGI

KABELSÄTZ • CABLEADOS • CÂBLAGES • KABELS • WIRE HARNESS • КОМПЛЕКТЫ ПРОВОДОВ • CHICOTES ELÉTRICOS • KÁBELKÖTEGEK

## cod. 3302.0001

- 2 pulsanti a 5 contatti
- 2 Schalter mit 5 Kontakten
- 2 pulsantes de 5 contactos
- 2 interrupteurs avec 5 contacts
- 2 schakelaars met 5 contacten
- 2 switches with 5 contacts



## cod. 3302.0017

- 7 pulsanti a 7 contatti con luce separata e 7 connettori
- 7 Schalter mit 7 Kontakten mit getrennter Beleuchtung und 7 Kombistecker
- 7 pulsantes de 7 contactos luces separadas y 7 conectores
- 7 interrupteurs avec 7 contacts avec éclairage séparé et 7 connecteurs
- 7 schakelaars met 7 contacten gescheiden aansluiting voor verlichting met 7 connectors
- 7 switches with 7 contacts with separated light and 7 connectors



with O.E.M. connectors

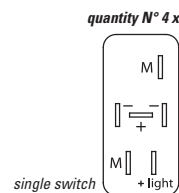

## cod. 3302.0020

- 4 pulsanti a 6 contatti con luce separata e 4 connettori
- 4 Schalter mit 6 Kontakten mit getrennter Beleuchtung und 4 Kombistecker
- 4 pulsantes de 6 contactos luces separadas y 4 conectores
- 4 interrupteurs avec 6 contacts avec éclairage séparé et 4 connecteurs
- 4 schakelaars met 6 contacten gescheiden aansluiting voor verlichting met 4 connectors
- 4 switches with 6 contacts with separated light and 4 connectors



quantity N° 4 x

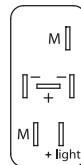

## cod. 3302.0022

- 3 pulsanti a 6 contatti con luce separata e 3 connettori
- 3 Schalter mit 6 Kontakten mit getrennter Beleuchtung und 3 Kombistecker
- 3 pulsantes de 6 contactos luces separadas y 3 conectores
- 3 interrupteurs avec 6 contacts avec éclairage séparé et 3 connecteurs
- 3 schakelaars met 6 contacten gescheiden aansluiting voor verlichting met 3 connectors
- 3 switches with 6 contacts with separated light and 3 connectors



quantity N° 3 x

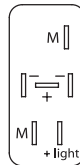

## cod. 3302.0029

- 3 pulsanti a 5 contatti e 3 connettori
- 3 Schalter mit 5 Kontakten und 3 Kombistecker
- 3 pulsantes de 5 contactos y 3 conectores
- 3 interrupteurs avec 5 contacts et 3 connecteurs
- 3 schakelaars met 5 contacten voor verlichting met 3 connectors
- 3 switches with 5 contacts and 3 connectors



with O.E.M. connectors

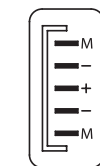

quantity N° 3 x

## cod. 3302.0025

- 3 pulsanti a 6 contatti con luce separata e 3 connettori
- 3 Schalter mit 6 Kontakten mit getrennter Beleuchtung und 3 Kombistecker
- 3 pulsantes de 6 contactos luces separadas y 3 conectores
- 3 interrupteurs avec 6 contacts avec éclairage séparé et 3 connecteurs
- 3 schakelaars met 6 contacten gescheiden aansluiting voor verlichting met 3 connectors
- 3 switches with 6 contacts with separated light and 3 connectors



with O.E.M. connectors



quantity N° 3 x

## cod. 3302.0032

- 3 pulsanti a 6 contatti con luce separata e 6 connettori
- 3 Schalter mit 6 Kontakten mit getrennter Beleuchtung und 6 Kombistecker
- 3 pulsantes de 6 contactos luces separadas y 6 conectores
- 3 interrupteurs avec 6 contacts avec éclairage séparé et 6 connecteurs
- 3 schakelaars met 6 contacten gescheiden aansluiting voor verlichting met 6 connectors
- 3 switches with 6 contacts with separated light and 6 connectors



quantity N° 2 x

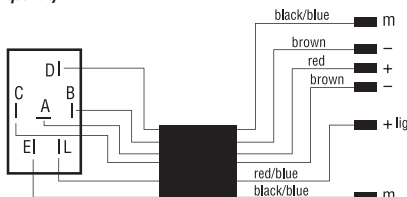

## cod. 3302.0009

- 2 pulsanti a 6 contatti con luce separata
- 2 Schalter mit 6 Kontakten mit getrennter Beleuchtung
- 2 pulsantes de 6 contactos luces separadas
- 2 interrupteurs avec 6 contacts avec éclairage séparé
- 2 schakelaars met 6 contacten gescheiden aansluiting voor verlichting
- 2 switches with 6 contacts with separated light



## cod. 3302.0040

- 3 pulsanti a 6 contatti con luce separata e 3 connettori
- 3 Schalter mit 6 Kontakten mit getrennter Beleuchtung und 3 Kombistecker
- 3 pulsantes de 6 contactos luces separadas y 3 conectores
- 3 interrupteurs avec 6 contacts avec éclairage séparé et 3 connecteurs
- 3 schakelaars met 6 contacten gescheiden aansluiting voor verlichting met 3 connectors
- 3 switches with 6 contacts with separated light and 3 connectors



quantity N° 3 x

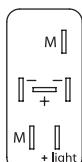

## cod. 3302.0018

- 2 pulsanti a 6 contatti con luce separata e 2 connettori
- 2 Schalter mit 6 Kontakten mit getrennter Beleuchtung und 2 Kombistecker
- 2 pulsantes de 6 contactos luces separadas y 2 conectores
- 2 interrupteurs avec 6 contacts avec éclairage séparé et 2 connecteurs
- 2 schakelaars met 6 contacten gescheiden aansluiting voor verlichting met 2 connectors
- 2 switches with 6 contacts with separated light and 2 connectors



quantity N° 2 x

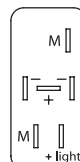

## cod. 3302.0041

- 4 pulsanti a 6 contatti con luce separata e 4 connettori
- 4 Schalter mit 6 Kontakten mit getrennter Beleuchtung und 4 Kombistecker
- 4 pulsantes de 6 contactos luces separadas y 4 conectores
- 4 interrupteurs avec 6 contacts avec éclairage séparé et 4 connecteurs
- 4 schakelaars met 6 contacten gescheiden aansluiting voor verlichting met 4 connectors
- 4 switches with 6 contacts with separated light and 4 connectors



quantity N° 4 x

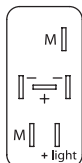

# TRANCIATORE

LOCHSCHNEIDER • SACABOCADOR • CISAILEUR • PONS VOOR DEURPANEEL • CUTTER • HOЖ • CORTADOR • KIVÁGÓSZERSZÁM

cod. 3304.0000

## • TRANCIATORE

per foratura tappo copriforo.

**IMPORTANTE:** Questo attrezzo è indispensabile per una corretta e soprattutto veloce installazione degli alzacristalli.

Richiedilo alla prima fornitura di alzacristalli

## • LOCHSCHNEIDER

zum Lochen der Abdeckblende.

**WICHTIG:** Dieses Werkzeug ist für einen korrekten und vor allem raschen Einbau der Scheibenheber unbedingt erforderlich.

(Bestellen Sie es zum schneidender Turverkleidung am besten gleich mit.)

## • CORTADORA

para taladrado del tapón de orificios.

**IMPORTANTE:** Esta herramienta es indispensable para una correcta y, sobre todo, rápida instalación de los elevavinas.

(Solicítalo en el primer suministro de elevavinas)

## • CISAILEUR

pour le perçage de la garniture de porte.

**IMPORTANT :** cet outil est indispensable pour réaliser une installation correcte et surtout rapide des lève-vitres.

(Ajoutez-le à votre première commande de lève-vitres)

## • PONS

voor doorboren deurpaneel.

**BELANGRIJK:** Dit werktuig is noodzakelijk voor een correcte en vooral snelle installatie van de raambedielingen.

(Aanvragen bij de eerste levering van raambedielingen)

## • CUTTER

for hole cover cap drilling.

**IMPORTANT:** This tool is indispensable for correct and above all quick installation of the power windows.

(Request it when first ordering power windows).

## • HOЖ

для прорезания круглых отверстий на дверной панели для заглушек.

**ВАЖНО:** Данный инструмент незаменим для правильной и быстрой установки электрических стеклоподъемников. (Запросите этот инструмент, когда будете делать первый заказ электрических стеклоподъемников).

## • CORTADOR

para a perfuração do painel e aplicação da tampa cobre-furo.

**IMPORTANTE:** Esta ferramenta é indispensável para uma instalação correta e, principalmente, rápida dos vidros elétricos.

Solicite-a ao fazer o seu primeiro pedido de vidros elétricos.

## • KIVÁGÓSZERSZÁM

nyílástakaró dugó kivágáshoz.

**FONTOS!** Ez a célszerszám elengedhetetlen az ablakemelők helyes és főként gyors beszereléséhez!

Kérje az első ablakemelő-rendelésnél!





cod. 3560.0003

### • MAV 6 - MODULO ALZACRISTALLO UNIVERSALE

dotato di 4 relé interni, abbinabile a sistemi di allarme radiocomandati per la chiusura di 2 alzacristalli elettrici d'origine di qualsiasi tipo e/o SPAL. Per l'AS 80 è previsto un apposito collegamento per usufruire della funzione AUX, (chiusura vetri manuale da TX).

### • MAV 6 - UNIVERSAL-FENSTERHEBERMODUL

mit 4 inneren Relais zur Kombination mit funkgesteuerten Alarmanlagen zum Schließen von zwei elektrischen Original-oder SPAL-Fensterhebern. Bei AS 80 ist ein Anschluß für die Sonderfunktion AUX vorgesehen (Fensterschließen über Fernbedienung).

### • MAV 6 - MÓDULO ALZACRISTALES UNIVERSAL

dotado de 4 relés internos, puede combinarse con sistemas de alarma radiomandados para el cierre de 2 alzacristales eléctricos de origen de cualquier tipo y/o SPAL. Para el AS 80 está prevista una específica conexión para poder usar la función AUX (cierre cristales manual con control remoto).

### • MAV 6 - MODULE LEVE-VITRES UNIVERSEL

équipé de 4 relais internes, pouvant être couplé à des systèmes d'alarme radiocommandés pour la fermeture de 2 lève-vitres électriques d'origine de tout type et/ou SPAL. Les AS 80 ont une connexion spéciale pour utiliser la fonction AUX (fermeture manuelle des vitres par radiocommande).

### • MAV 6 - UNIVERSELE MODULE VOOR ELEKTRISCH BEDIENDE RAMEN

uitgerust met 4 interne relais, kan gekoppeld worden aan alarmsystemen met radiobediening voor de sluiting van 2 elektrische raambedieningen van gelijk welk type en/of SPAL. Voor AS 80 is een speciale verbinding voorzien om gebruik te kunnen maken van de functie AUX (handbediende sluiting ruiten vanuit TX).

### • MAV 6 - UNIVERSAL POWER WINDOW MODULE

4 internal relays, this module can be joined to remote controlled alarms to close 2 original and/or SPAL power window units. Spal AS 80 have a special connection to use the AUX function (manual window closing by remote control).



### • MAV 6 - УНИВЕРСАЛЬНЫЙ МОДУЛЬ ЭЛЕКТРИЧЕСКИХ СТЕКЛОПОДЪЕМНИКОВ

4 встроенных реле, этот модуль может быть подключен к автосигнализации для поднятия стекол 2-мя оригинальными стеклоподъемниками и/или стеклоподъемниками SPAL при подаче сигнала с брелка дистанционного управления автосигнализации. SPAL AS 80 имеют специальный разъем для использования функции AUX (поднятие стекол SPAL при подаче сигнала с брелка дистанционного управления автосигнализации).

### • MAV 6 - MÓDULO ELEVADOR DE VIDROS UNIVERSAL

provido de 4 relés internos, associável a sistemas de alarmes comandados por controle remoto para o fechamento de 2 vidros elétricos originais de qualquer tipo e/ou SPAL. Para o AS 80 foi prevista uma conexão especial para tirar proveito da função AUX (fechamento manual dos vidros comandado por controle remoto).

### • MAV 6 - UNIVERZÁLIS ABLAKEMELŐ MODUL

4 belső relével, összekapcsolható távirányított riasztórendszerekkel 2 db bármilyen típusú gyári széria és/vagy SPAL-ablakemelő zárásához. AS 90 rendelkezik egy külön csatlakozóval, így használható az ablakok zárásához.



cod. 3560.0011

### • MAV 8 - MODULO ALZACRISTALLO

abbinabile a sistemi di allarme radiocomandati per la chiusura di 2 alzacristalli elettrici d'origine e/o SPAL (solo con polarità negativa a riposo). Per AS 80 è previsto un apposito collegamento per usufruire della funzione AUX, (chiusura vetri manuale da TX).

### • MAV 8 - FENSTERHEBERMODUL

zur Kombination mit funkgesteuerten Alarmanlagen zum Schließen von 2 elektrischen Original-oder SPAL-Fensterhebern (Minuspol im Ruhezustand). Bei AS 80 ist ein Anschluß für die Sonderfunktion AUX vorgesehen (Fensterschließen über Fernbedienung).

### • MAV 8 - MÓDULO ALZACRISTALES

puede combinarse con sistemas de alarma radiomandados para el cierre de 2 alzacristales eléctricos de origen y/o SPAL (sólo con polaridad negativa en reposo). Para el AS 80 está prevista una específica conexión para poder usar la función AUX (cierre cristales manual con control remoto).

### • MAV 8 - MODULE LEVE-VITRES

pouvant être couplé à des systèmes d'alarme radiocommandés pour la fermeture de 2 lève-vitres électriques d'origine et/ou SPAL (uniquement à polarité négative en veille). Les AS 80 ont une connexion spéciale pour utiliser la fonction AUX (fermeture manuelle des vitres par radiocommande).

### • MAV 8 - MODULE VOOR ELEKTRISCH BEDIENDE RAMEN

kan gekoppeld worden aan alarmsystemen met radiobediening, voor de sluiting van 2 originele en/of SPAL elektrische raambedieningen (alleen met negatieve polariteit in ruststand). Voor AS 80 is een speciale verbinding voorzien om gebruik te kunnen maken van de functie AUX (sluiting ruiten vanuit TX).

### • MAV 8 - ELECTRIC POWER WINDOW MODULE

It can be joined to remote controlled alarm systems to close 2 original and/or SPAL power window units (with negative polarity only). Spal AS 80 have a special connection to use the AUX function (manual window closing by remote control).

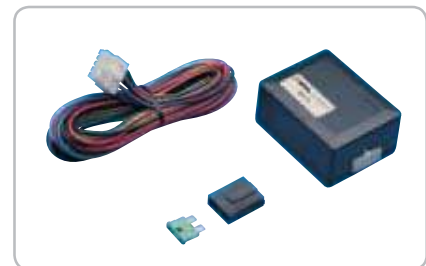

### • MAV 8 - МОДУЛЬ ЭЛЕКТРИЧЕСКИХ СТЕКЛОПОДЪЕМНИКОВ

Этот модуль может быть подключен к автосигнализации для поднятия стекол 2-мя оригинальными стеклоподъемниками и/или стеклоподъемниками SPAL при подаче сигнала с брелка дистанционного управления автосигнализации (только с отрицательной полярностью). SPAL AS 80 имеют специальный разъем для использования функции AUX (поднятие стекол SPAL при подаче сигнала с брелка дистанционного управления автосигнализации).







### • MAV 8 - MÓDULO ELEVADOR DE VIDROS

associável a sistemas de alarmes comandados por controle remoto para o fechamento de 2 vidros elétricos originais e/ou SPAL (apenas com polaridade negativa em repouso). Para o AS 80 foi prevista uma conexão especial para tirar proveito da função AUX (fechamento manual dos vidros comandado por controle remoto).

### • MAV 8 - ABLAKEMELŐ MODUL

távirányított riasztórendszerekkel összeköthető 2 gyári és/vagy SPAL elektromos ablakemelő zárásához (csak ha nyugalmi állapotban negatív pólusú). Az AS 90 rendelkezik egy külön csatlakozóval, így az használható az ablakok zárásához.

## SOMMARIO

Cod. 1740.0007 	15	Cod. 3301.0143.....	22	Cod. 3303.0171.....	20
Cod. 1740.0010.....	18	Cod. 3301.0144.....	23	Cod. 3303.0172.....	20
Cod. 1740.0048.....	21	Cod. 3301.0155.....	23	Cod. 3304.0000.....	26
Cod. 1740.0049.....	16	Cod. 3302.0001.....	15-18-24	Cod. 3304.0017.....	15
Cod. 1740.0050.....	21	Cod. 3302.0009.....	15-16-18-25	Cod. 3304.0018 	15
Cod. 1740.0052.....	15	Cod. 3302.0017.....	13-14-24	Cod. 3304.0030.....	18
Cod. 1740.0061A.....	18	Cod. 3302.0018.....	6-11-19-25	Cod. 3304.0041.....	16
Cod. 1740.0068.....	18	Cod. 3302.0020.....	19-24	Cod. 3304.0049.....	18
Cod. 1740.0073.....	19	Cod. 3302.0022.....	7-8-16-24	Cod. 3304.0056.....	18
Cod. 1740.0083A.....	21	Cod. 3302.0025.....	5-12-24	Cod. 3304.0059.....	22
Cod. 1740.0085.....	19-21	Cod. 3302.0029.....	15-24	Cod. 3304.0079.....	22
Cod. 1740.0088.....	21	Cod. 3302.0032.....	9-10-17-25	Cod. 3304.0105.....	12
Cod. 1740.0090.....	12	Cod. 3302.0040.....	20-25	Cod. 3304.0111.....	22
Cod. 1740.0091A.....	21	Cod. 3302.0041.....	20-25	Cod. 3304.0111.....	22
Cod. 1740.0092A.....	21	Cod. 3303.0002.....	15	Cod. 3304.0121.....	11
Cod. 1740.0094.....	14-21	Cod. 3303.0024.....	14-17	Cod. 3304.0122.....	11
Cod. 1740.0095A.....	11-13	Cod. 3303.0025.....	17	Cod. 3304.0126 	15
Cod. 1740.0099.....	14-17	Cod. 3303.0069.....	12	Cod. 3304.0127.....	16
Cod. 1740.0103.....	19	Cod. 3303.0070.....	12	Cod. 3304.0128.....	17
Cod. 1740.0110A.....	6-7-8-20	Cod. 3303.0071.....	12	Cod. 3304.0140.....	19
Cod. 1740.0111A.....	9-10	Cod. 3303.0079.....	11-13	Cod. 3304.0141.....	19
Cod. 1740.0114.....	5	Cod. 3303.0081.....	11	Cod. 3304.0150.....	22
Cod. 1740.0125.....	21	Cod. 3303.0091.....	19	Cod. 3304.0160.....	6
Cod. 1740.0128A.....	22	Cod. 3303.0097.....	6-7	Cod. 3304.0161.....	6
Cod. 1795.0025.....	22	Cod. 3303.0098.....	6-7-8	Cod. 3304.0162.....	7
Cod. 3300.0013.....	4	Cod. 3303.0099.....	13-14-20	Cod. 3304.0162.....	7
Cod. 3300.0021.....	4	Cod. 3303.0100.....	13-14	Cod. 3304.0167.....	9
Cod. 3300.1000 	4	Cod. 3303.0103 DX+SX.....	9	Cod. 3304.0169.....	14
Cod. 3301.0027.....	23	Cod. 3303.0115.....	5	Cod. 3304.0170.....	13
Cod. 3301.0058.....	22	Cod. 3303.0116.....	5	Cod. 3304.0171.....	14
Cod. 3301.0133.....	23	Cod. 3303.0117.....	5	Cod. 3304.0174.....	5
Cod. 3301.0134.....	23	Cod. 3303.0125.....	10	Cod. 3304.0188.....	10
Cod. 3301.0135 	23	Cod. 3303.0127.....	10	Cod. 3304.0219.....	8
Cod. 3301.0136 	23	Cod. 3303.0139.....	8	Cod. 3304.0262.....	20
Cod. 3301.0137.....	23	Cod. 3303.0140.....	8	Cod. 3560.0003.....	27
Cod. 3301.0138.....	23	Cod. 3303.0168.....	20	Cod. 3560.0011.....	27
Cod. 3301.0092.....	22	Cod. 3303.0170.....	20		



## UNIVERSAL APPLICATIONS

